

# REDLINE SOIL ROLLER



## DRS120D

### Technical Data

#### Masses

|  |                    |
|--|--------------------|
| Operating mass (incl. Canopy)            | 11400 kg           |
| Max. operating mass incl. pad shells     | 12800 kg           |
| Module mass (front/rear)                 | 6800kg/<br>4600 kg |
| Module mass with Pad shells (front/rear) | 8200kg/<br>4600 kg |

#### Dimensions

|               |         |
|---------------|---------|
| Drum width    | 2130 mm |
| Drum diameter | 1500 mm |

#### Compaction

|  |                   |
|--|-------------------|
| Static linear load                     | 32 kg/cm          |
| Nominal amplitude (high/low)           | 1.8 mm/<br>0.9 mm |
| Vibration frequency (high/low)         | 33 Hz/33 Hz       |
| Centrifugal force (high/low amplitude) | 250 kN/<br>130 kN |

#### Engine

|                    |                      |
|--------------------|----------------------|
| Manufacturer/Model | Dynapac              |
| Type               | 4 cyl, water-cooled  |
| Rated power        | 105 hp @<br>2200 rpm |
| Electrical system  | 12V                  |
| Fuel tank capacity | 280l                 |

#### Traction

|                              |            |
|------------------------------|------------|
| Speed range                  | 0 - 8 km/h |
| Theoretical max. gradability | 53%        |
| Steering angle               | +/- 38°    |

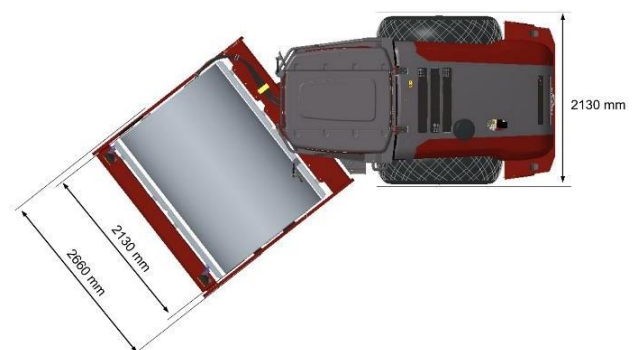
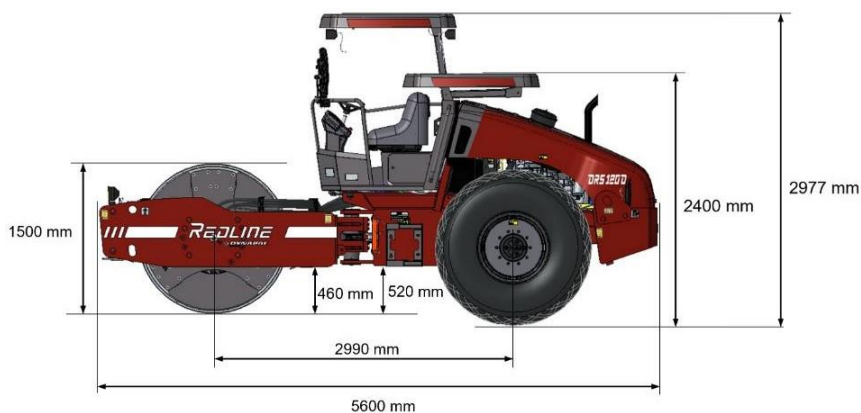

We reserve right to change specifications without notice. Photos and illustrations do not always show standard versions of machines.

The above information is a general description only, all information are supplied without liability.

