

REDLINE Asphalt Paver

DRF25 - 70C

Technical Data



Dimensions	
Transport width incl. DRV60 TVE	3 m
Transport length	6.15 m
Transport height	3.10 m
Max. working width	9 m
Weight incl. DRV60 TVE	18.5 t
Weight incl. DRV51 TVE	18.2 t
Capacity	
Theoretical placement capacity	750 t/h
Placement thickness (max)	310 mm
Max. paving level below zero	-150 mm
Material hopper	
Capacity	6m ³
Hopper width, internal	3295 mm
Dumping height	555 mm
Seperate hopper control	Yes
Conveyor	
Conveyor type	Dual bar feeder
Conveyor width	2 x 655 mm
Conveyor control	2 independent conveyors with limit switches and speed control
Operation	
Operator console	Ergonomic dashboard with toggle switches, Slideable left/right
Platform	Dual seat concept with foldable canopy

Engine	
Type	6 cylinder watercooled diesel engine with hydrostatic fan drive
Manufacturer	Cummins
Type	QSB 6.7 - C173
Rated power	129kW (175hp) @2200 rpm
Emissions according to	Tier 3
Electrical system	24V
Fuel tank capacity	320 L
Undercarriage	
Type	Hydrostatic final direct drives, gear boxes integrated in the crawler frame
Crawler length x width	2900 mm x 320 mm
Paving speed	up to 30 m/min
Transport speed	up to 4 km/h
Ramp up angle front	15°
Auger	
Auger diameter	380 mm
Auger height adjustment	Mechanic
Auger control	2 independent augers with Ultrasonic sensor and proportional speed control
Reversible rotational direction	Yes
Auger height adjustment	Infinetely variable by 250mm

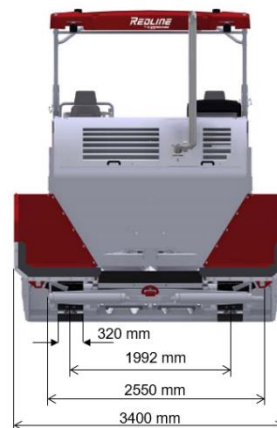
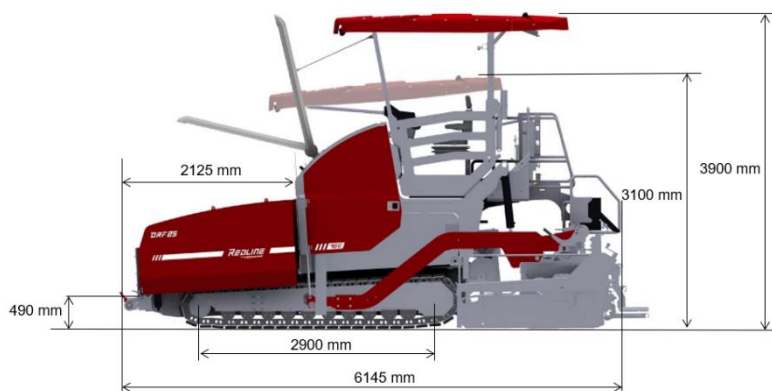

We reserve the right to change specifications without notice. Photos and illustrations do not always show standard versions of machines.

The above information is a general description only, all information are supplied without liability.

Screeds	Basic width	Hydr. Extendable up to	Max. working width	Compaction	Heating	Weight
DRV51TVE	2.55 m	5.10 m	8.8 m	Tamper Vibration	Electric	3400 kg
DRV60TVE	3.00 m	6.00 m	9.0 m	Tamper Vibration	Electric	3850 kg