

REDLINE

Reversible plates



RR200D

Technical Data

Masses

Operating mass	196 kg
Net weight	191 kg
Maximum working speed	20 m/min
Centrifugal force	30 kN
Frequency	81 Hz
Max gradeability	55 %
Amplitude	1.9 mm

Dimensions

Height	750 mm
Height H1	1150 mm
Length L1	1230 mm
Length plate L	710 mm
Width plate W	500 mm

Engine

Manufacturer/Model	Greaves 1520
Type	Air cooled, Diesel
Rated power	3.72 kW @ 3,450 rpm
Fuel tank capacity	3.6 l

Features

Features

- Control handle with vibration isolation
- Control lever lock in transport position
- Reverse drive protection
- High wear resistant base plate
- All around protection hood
- All around protection for V-belt
- One point lift
- Recoil started
- Self-cleaning plate technology
- High wear-resistant forged base plate

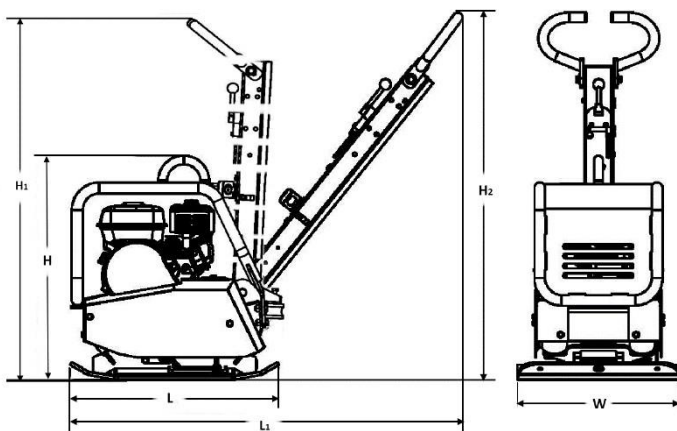

We reserve right to change specifications without notice. Photos and illustrations do not always show standard versions of machines.

The above information is a general description only, all information are supplied without liability.

