

REDLINE Forward Plates



RV50

Technical Data

Masses		Features
Operating mass	53 kg	Foldable steering handle with vibration isolation
Basic mass	50 kg	Highly wear resistance wear plate
Traction		All-round protection for V-belt
Maximum working speed	24 m/min	Protection frame for the power pack
Max. Gradability	36.4 %	Carrying handles
Compaction		One point lift
Centrifugal force	11 kN	Puncture-proof transport wheels
Frequency	100 Hz	
Amplitude	2.4 mm	
Engine		
Manufacturer Model	Honda GX 160	
Type	Petrol	
Power	3.7 kW @ 3,450 rpm	
Dimensions		
Height (H)	440 mm	
Height (H1)	475 mm	
Length (L)	484 mm	
Length plate (L1)	760 mm	
Width plate	350 mm	

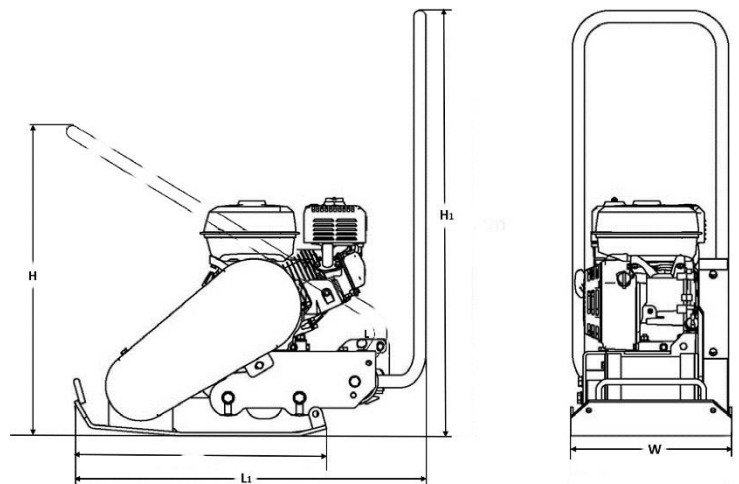

We reserve right to change specifications without notice. Photos and illustrations do not always show standard versions of machines.

The above information is a general description only, all information are supplied without liability.

