

INSTRUCTION MANUAL

DRA30

Asphalt Roller



SERIAL NUMBER:
10300619HME011517

ENGINE:
Dynapac- 275 DI TU

Part Number:
4812333211_B-EN





Manual Revisions

Table 1: Revision History

REV. NO.	DATE	REVISION
1	Dec' 2021	New release
2	May' 2022	Revised with new branding guideline

Customer Acknowledgment

- Dynapac reserves the right to make any changes or modifications without prior notice and without incurring any liability to retrofit machines previously shipped from the factory.
- Dynapac will not be held responsible for any damages caused by unauthorized modification of the machine and its associated equipment.
- The manufacturer is not liable for damages caused by inappropriate use.
- Damage that occurs as a result of substandard repairs, as well as injury to personnel or damage to equipment that is attributable to older un-repaired damage, is not covered by the customer warranty policy. Always refer to your customer warranty policy.
- Always refer to equipment documentation for correct operation and repair procedures.



Table of Contents

Section 1: Introduction

1.1 General Information	1
Instruction Manual Location	2
Receiving the Roller	2
Identification Data	2
Roller Identification	3
Engine Identification	4
1.2 Roller Description	5
Identification of Major Components	5
Diesel Engine.....	6
Electrical System.....	7
Main and Light Fuses	7
Propulsion System/Transmission	8
Brake system	8
Secondary/Parking Brake	8
Steering System.....	8
FOPS and ROPS.....	8
Roller Applications	9
Designated Applications	9
Non-Designated Applications	9

Section 2: Safety First

2.1 General Information	11
Warnings and Cautions	12
Personnel Protective Equipment	12
Tools and Equipment	12
Operating Safety	13
Before Starting the Engine	13
Starting the Equipment	13
Parking the Roller	13
Driving Near Edges	13
Slopes	13
Gas Spring	14
Hydraulic Maintenance Safety	14
Cylinder Repairs or Replacement	14
Handling Fluids and Oil	14
Transporting	15
2.2 Equipment Safety Decals	16



Table of Contents

Section 3: Special Instructions

3.1 Operational Limitations	17
Standard Lubricants and Other Recommended Oils and Fluids	17
Higher Ambient Temperatures	17
Lower Ambient Temperature - Freeze Risk	17
Temperatures	17
High Pressure Cleaning	18
Ambient Temperature Range	18
Operating Conditions for Stability	18
Grade Limitations	18
Fire Fighting	18
Roll Over Protective Structure (ROPS)	19
Battery Handling	19
Jump Starting	19

Section 4: Specifications

4.1 Weight and Dimensions	21
Diesel Engine	22
Fluid Volume	23
Working Capacity	23
Hydraulic System	23

Section 5: Operation Controls

5.1 Instruments and Controls	25
Starter Switch	26
Throttle Lever	26
Vibration On/Off Switch	26
Emergency Stop	27
Forward/Neutral (FNR) Lever	27
Sprinkler Switch	27
Seat Buzzer	27
Horn Button	28
Vibration Man/Auto Switch	28
Vibration Selector Switch	28
Fuse Box	28
Driving Lights Switch	28
Working Lights Switch(Optional)	29



Hazard Warning Lights Switch.....	29
Rotating Beacon Switch (Optional)	29
Direction Indicator Switch	29
Parking Brake On/Off Switch	29
Control Panel.....	30
Control Panel Warnings Symbols	30
Control Panel Notification Symbols	31

Section 6: Inspections and Operations

6.1 General Information	33
General Checks.....	33
Operator Areas.....	33
Check Engine Oil Level.....	34
Check Engine Coolant Level.....	34
Check the Fuel Level.....	35
Check Batteries	35
Verify the Controls	35
6.2 Before Starting the Engine	36
Seat (Standard) Adjustment.....	36
Check the Instruments and Lamps	37
Interlock	37
6.3 Operating the Roller	38
Operation.....	38
Vibration on One Drum	39
Braking.....	39
Normal Braking	39
Emergency Braking	39
Switching Off.....	40
6.4 Lifting and Handling	41
Locking the Articulation.....	41
Lifting the Roller	41
6.5 Towing the Roller	42
Towing Information	42
Towing.....	42
6.6 Transporting the Roller	44
Transportation Procedures.....	44
Safety Precautions.....	44
Operator Checklist	44
Start Up	44



Table of Contents

Before Driving	44
Securing for Loading	45
6.7 Special Conditions	46
Cold Weather Conditions	46
Hot Weather Conditions	46
High Altitude Conditions	46
Long-term Parking	46

Section 7: Maintenance

7.1 General Information	47
7.2 Maintenance Schedule	48
Maintenance Schedule Information	48
7.3 Refill Capacities/Lubricants	52
General Information	52
Lubrication Chart	53
Refill Capacities	53
7.4 Standard Torque Values	55
Head Markings	55
Recommended Torques	55
7.5 Maintenance as Required	57
Service as Required	57
Clean the Roller	57
Loose Bolted Connections	57
Air Cleaners	57
Air Cleaner Indicators	57
Connections and Ducts	58
Air Cleaner Pre-Cleaner	58
Air Cleaner Main Filter	58
Hose and Clamps	59
Engine	60
Batteries	60
Check Electrolyte Level	61
Fuel Tank	61
Lowering of Engine Hood	62
Water Tank	63
Brakes	63
Sprinkler System	64
7.6 Lubrication and Filters	65





Section 1: Introduction

1.1 General Information

This manual contains basic safety information, basic operation instructions, and preventive maintenance information of the Dynapac DRA30 roller.

The purpose of this manual is to provide the operator and site maintenance personnel the knowledge of the fundamental rules and criteria to be followed for on-site use and maintenance of a DRA30 roller.

The operator and site maintenance personnel must read and fully understand this instruction manual before operating or servicing the roller. This manual has been organized to present the safety precautions, operation requirements, and appropriate information needed to:

- Safely operate the DRA30 roller while achieving optimum production.
- Understand the operating principal of each system associated with the DRA30 roller.
- React effectively and safely to emergency and alarm conditions.
- Perform the necessary pre-operational and post-operational checks on the roller.

If any part of this manual cannot be understood, contact the supervisor or local Dynapac distributor. This is an essential condition for working safely with the DRA30 roller. The correct DRA30 operation, use, and regular maintenance are also essential elements to provide the highest performance and safety.

Note Always keep the Safety and Instruction manuals on the roller and available to the operator and the helper. Always provide the model and serial number of the roller when contacting the local Dynapac service or parts office.

Instruction Manual Location

The instruction manuals are located under operator seat within easy access.

Figure 1-1: Instruction manual Location

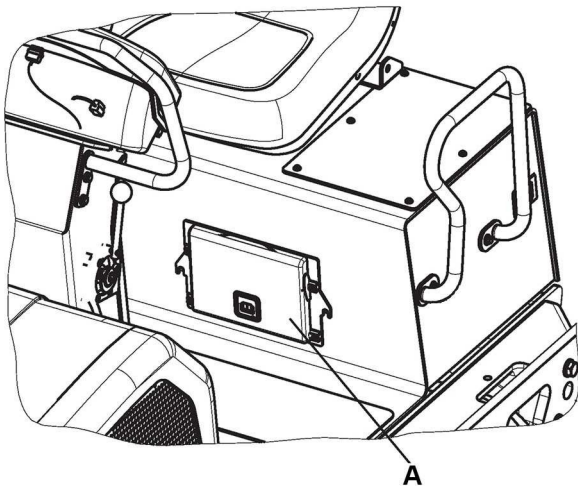

A Manual location

Receiving the Roller

The DRA30 roller has been tested, accurately checked, and prepared for shipment. Every part of the roller is accurately checked before being shipped from the factory.

When receiving the DRA30 roller and before unpacking the equipment, check if damage has occurred during transport and if any parts are missing.

Check the equipment by consulting the shipment documents.

If the goods are damaged or if parts are missing, inform the freight agent and raise a complaint against it.

Identification Data

An exact description of the model type and the serial number of the roller facilitates fast and efficient response from our parts and service support operations.

Provide the model type and serial number while contacting the local Dynapac service or parts office.

Enter your roller data on the following lines to maintain roller and engine information necessary to facilitate fast and efficient response from our parts and service support operations:

Model: _____

Roller Serial Number: _____

Chassis VIN Number: _____

Year of Manufacture: _____

Engine (Mfg. and Type of Engine): _____

Engine Serial Number: _____



Roller Identification

The machine Product Identification Number (PIN) plate is located on left hand side of the rear frame. The PIN number is a 17-digit number which provides information about manufacturer, family model, check letter, no coding, production unit, and serial number.

Figure 1-2: Location PIN

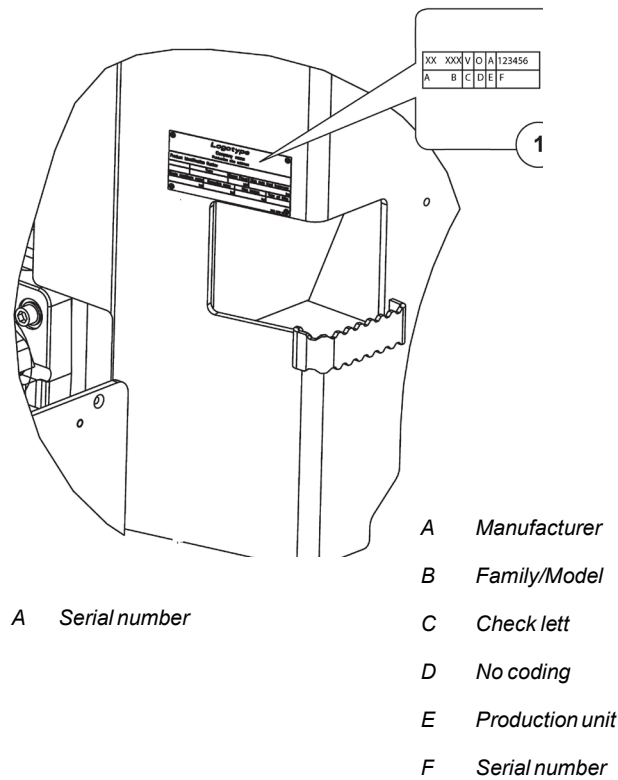

Pin number is punched on top right side of front frame.

Figure 1-3: Location PIN

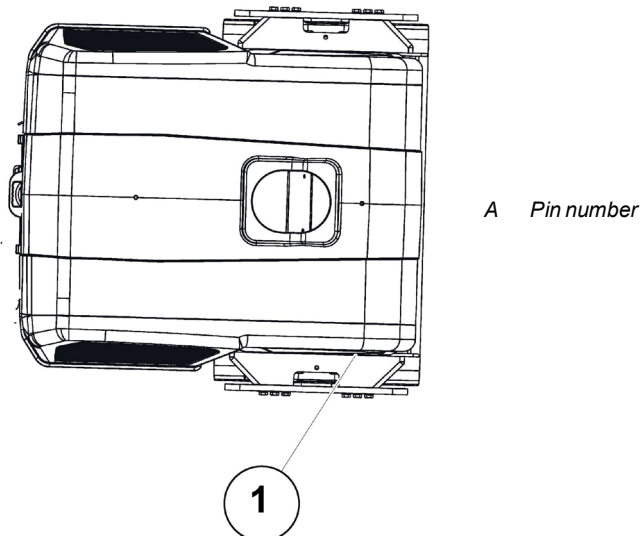

Engine Identification

Figure 1-4: Identification Plate

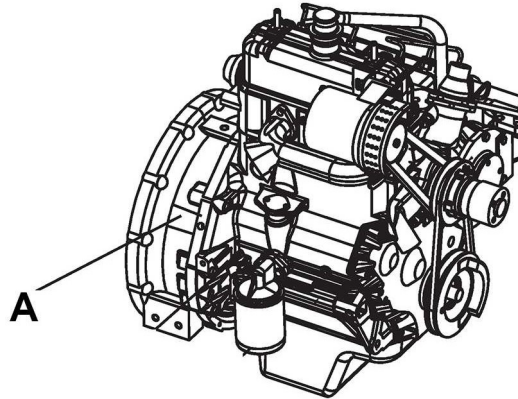

A *Engine identification plate*

The engine identification plate located on flywheel housing near engine oil filter. The engine identification plate provides model identification and other important data about the engine. Refer to the engine operation and maintenance manual for further information on the identification information. Have the following engine data available when communicating with an authorized repair location or engine dealer. The data on the engine identification plate is mandatory when sourcing service parts:

- Engine serial number
- Model



1.2 Roller Description

DRA30 are two self-propelled vibratory tandem rollers in the three metric tonnes class featuring 1200 mm wide drums. The machines are equipped with drive, brakes, and vibration on both drums.

To permit optimum performance on a wide range of applications and site requirements, the roller is equipped with:

Diesel engine

Electrical system

Propulsion system/transmission

Brake system

Secondary/parking brake

Steering system

FOPS and ROPS/Canopy

Identification of Major Components

Figure 1-5: Major Components Right Side

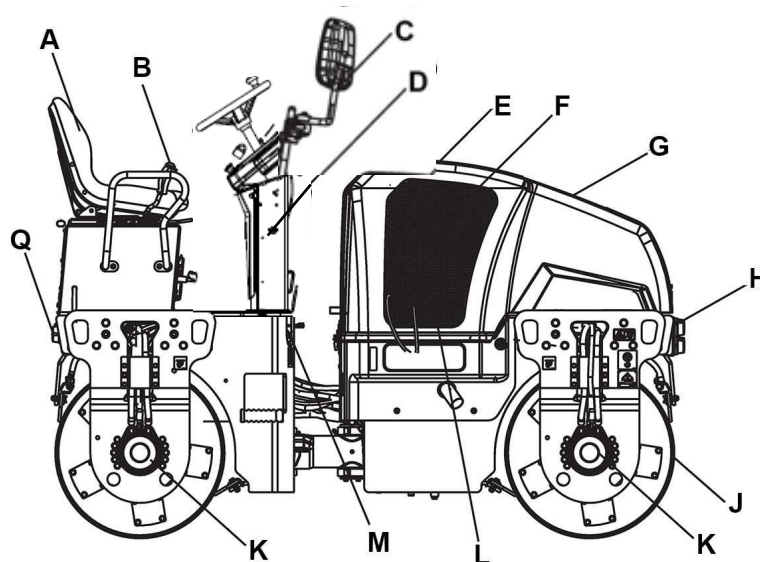

A	Seat	E	Hood	J	Drum
B	Forward and reverse lever	F	Engine	K	Propulsion pump
C	Mirror (Optional)	G	Water tank	L	Propulsion pump
D	Steering console	H	Lights	M	Fuel tank

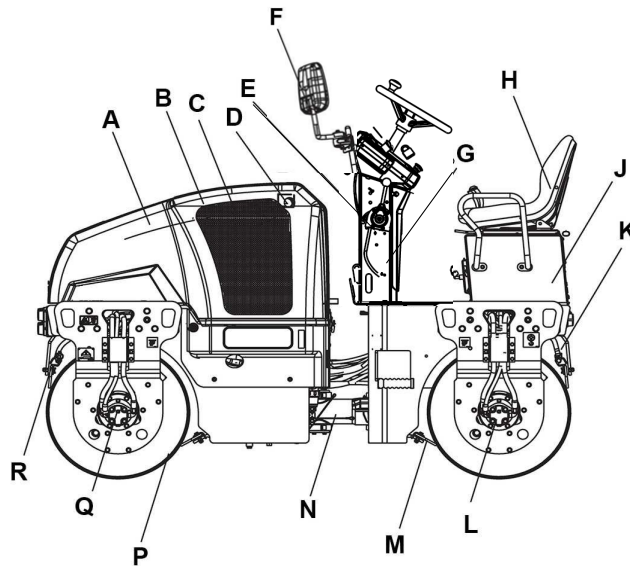

Figure 1-6: Major Components Left Side

A	Hood	G	Steering console	N	Steering joint
B	Engine	H	Seat	P	Drum
C	Cooler	J	Platform	Q	Vibration motor
D	Air Cleaner	K	Sprinkler system	R	Scraper
E	Throttle lever	L	Vibration motor		
F	Mirror (Optional)	M	Scraper		

Diesel Engine

The machine is equipped with a water-cooled, straight three cylinder, and four-stroke diesel engine.



Electrical System

The roller is equipped with 12-V electrical system and 3-A AC alternator.

Figure 1-7: Electric System

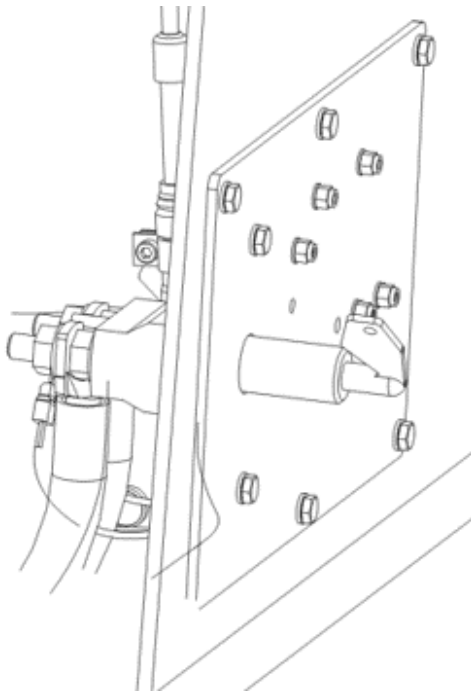
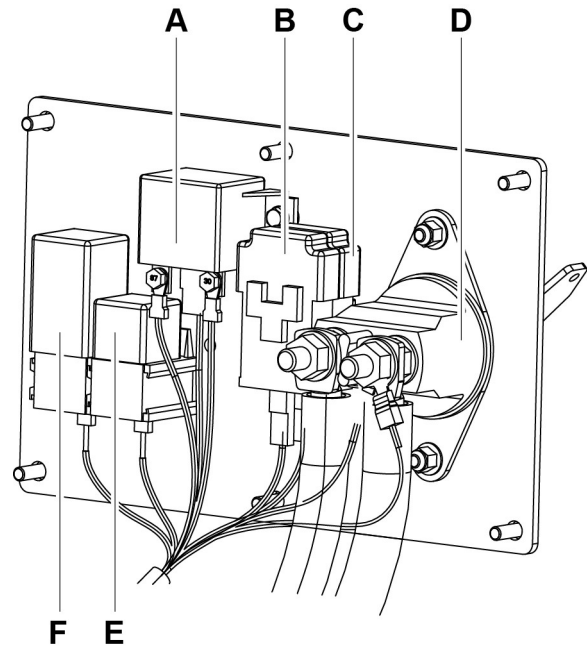

Figure 1-8: Fuses



- | | | | |
|---------|---------------------------|---|-----------------------------|
| A | 100-A Power relay | E | 30-A Mini relay for starter |
| B and C | 30-A Main fuses | F | Timer relay |
| D | Battery disconnect switch | | |

Main and Light Fuses

The main fuse and light fuse are placed near to the battery disconnect switch.

On the same bracket, timer relay and 100-A power relay for stop solenoid are placed.

Table 1-1: Placement of Fuses

F3	Main fuse	30 A
F4	Fuse-starter relay	30 A

Fuse Boxes in Switch Box

The flat pin, type C (medium) fuses and first cavity 20-A fuse are used for driving lights.



Figure 1-9: Fuses- Box

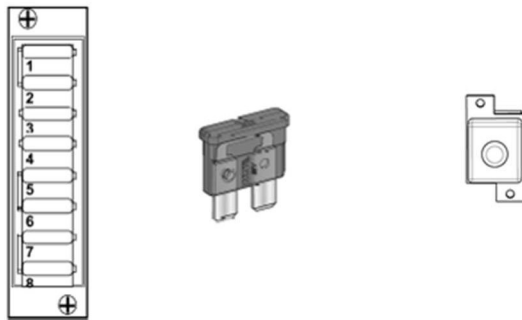

A

B

C

A Fuse box

C Fuse for driving lights

B Fuse

Table 1-2: Fuse Function and Amperage

Sl. No	Function	Amperage
1	Main fuse (Emergency/ Parking switch)	15 A
2	Emergency/Keypad	10 A
3	Empty	
4	ECU/Flash input fuse	30 A
5	Back up alarm SW	10 A
6	ECU	30 A
7	Sprinkler Relay	10 A
8	Spare	10 A

Table 1-3: Fuses for light

Sl No	Function	Amperage
1	Driving lights	20 A
2	Spare	10 A

Propulsion System/ Transmission

The propulsion system is a hydrostatic system with a hydraulic pump supplying two motors connected in parallel. The motors drive the front and rear drums.

The speed of the machine is proportional to the deflection/angle of the control lever from neutral.

Brake system

The brake system consists of a service brake, secondary brake, and parking brake. The service brake is hydrostatic and is activated by moving the control lever to neutral.

Secondary/Parking Brake

The secondary and parking brake system consists of spring multiple disc brakes in the motors. The brakes are released with hydraulic pressure and are operated with a switch on the instrument panel.

Steering System

The steering system is a hydrostatic system. The control valve on the steering column distributes the flow to the control cylinder, which actuates the articulation.

The steering angle is proportional to the deflection of the steering wheel.

FOPS and ROPS

FOPS is the abbreviation for Falling Object Protective Structure (roof protection) and ROPS is the abbreviation for Roll Over Protective Structure. If any part of the FOPS/ROPS structure's protective construction displays plastic deformation or cracks, the FOPS/ROPS structure must be replaced immediately. Never perform unauthorized modifications on the FOPS/ ROPS structure.



Roller Applications

The DRA30 roller is built in accordance with international standards and recognized safety rules. Nevertheless, misuse may constitute a risk to the life and limb of the user or third parties and may cause damage to the roller or other material property.

The DRA30 roller must be used in accordance with its designated use as described in this manual. The roller must only be operated by trained; safety-conscious persons who are fully aware of risks involved in operating the roller. Any functional disorders, especially those affecting the safety of the roller, must be corrected immediately.

Designated Applications

The DRA30 roller is designed primarily for compaction of asphalt. It has excellent compaction capacity for reinforcement layers and bearing courses. The roller is mainly intended for compacting asphalt on streets and minor roads in towns. It has sufficient capacity to follow a small asphalt paver.

Non-Designated Applications

The DRA30 roller is not designed to use as a ladder, support, or a work surface. It is not used to carry or transport passengers or equipment. The manufacturer/supplier cannot be held liable for any damage resulting from such use. The risk of such use lies entirely with the user.

Operating the DRA30 roller within the limits of its designated use also involves compliance with the inspection and maintenance directives contained in the operating manual.

This page is intentionally left blank

Section 2: Safety First

2.1 General Information

This information is intended as a guide for trained and qualified personnel who are aware of the dangers involved in handling potentially hazardous equipment. It is not intended to contain a complete list of all safety precautions which should be observed by personnel using this equipment.

Before you operate, maintain, work around, or in any other way use this equipment:

Note Read and study the Safety Manual, and this Instruction Manual.

Note Ensure that all instructions in the maintenance section are followed. Failure to obey instructions or warnings could result in injury or death.

- Those who operate, maintain, and work on equipment must be competent.
- The maintenance and service of this equipment involves risks both to personnel and equipment and must be performed only by qualified personnel exercising caution.
- Personnel engaged in the operation, maintenance, or servicing of this equipment are urged to become familiar with First Aid theory and practices.
- During operation of this equipment, local safety, and fire protection standards must be observed.
- Do not use the roller in need of adjustment or repair. Mount and dismount the roller when it is stationary. Use the intended grips and rails. Always use the three-point grip (both feet and one hand, or one foot and both hands) when mounting or dismounting the machine. Do not jump on or off a moving machine.
- It is strictly advised to use the ROPS (Roll Over Protective Structure), when the machine is operated on unsafe ground.
- Drive slowly and carefully during the sharp bends or during the uneven ground.
- Avoid driving across slopes. Drive straight up or straight down the slope.
- The seat belt must be fastened while driving.
- Replace all the lost and damaged safety labels.
- Keep the roller in good working condition.
- Safety measures during refuelling:
 - Make sure to stop the engine.
 - Do not smoke.
 - Do not use naked flames in the vicinity.
 - Ground the nozzle of the filling device against the tank to prevent sparks.

This safety summary includes general safety precautions and instructions that must be understood and applied during operation and maintenance to make sure personnel safety and protection of equipment. Before performing any task, the WARNINGS, CAUTIONS, and NOTES included in that task shall be reviewed and understood.

Warnings and Cautions

Throughout the manual, Warnings, Cautions, and Notes symbols are used to designate instructions of particular importance. Look for these symbols which point out items of extreme importance to you and your co-workers' safety. Read and understand thoroughly. Heed the warning and follow the associated instructions. In this manual, these terms have the following significance:



WARNING ! Marks a danger or a hazardous procedure that can result in life threatening or serious injury if the warning is ignored.



CAUTION ! Marks a danger or hazardous procedure that can result in damage to the machine or property if the warning is ignored.

Note Note is used for supplementary information not directly effecting safety or damage to equipment. Note can also refer to special information on the efficient use of the roller.

Modifications

The equipment is designed for safe operation. Do not do anything that may hamper the safety features or structural integrity of the equipment

Do not make any unauthorized modifications to this equipment. Dynapac cannot be held responsible for any accidents, incidents, or damage to persons or property that are related to the use of modified equipment.

Personnel Protective Equipment

Anyone working around the roller must wear approved safety equipment (safety shoes or protective footwear, safety glasses, hearing protection, hard hat, gloves, respirator, and the like) when operating or maintaining the machine. Wear close fitting clothing and confine long hair. Operating requires full attention of the operator. Do not wear radio or music headphones while operating.

Tools and Equipment



Tools, lifting gear, fastening devices, jacks, and other working equipment must be in safe operational working conditions.



Equipment or components which are being fitted or removed or where their installation position is being changed, must be secured against unintentional movement, slipping, or falling over. Use suitable lifting gear or suspension/ support devices.



Systems and units (tensioning units) must be depressurized in an appropriate manner before opening.



Damaged hydraulic or mechanical pre-tensioned spring elements must be exchanged as a completed unit. Further information can be found in the respective component descriptions and/ or fitting and removal instructions.



Operating Safety

Know the working area. Familiarize with work site obstructions and any other potential hazards in the area.

Before Starting the Engine

- Inspect the roller for potential hazards.
- Adjust the rear-view mirrors for good visibility.
- Make sure that the controls are in the neutral position and the parking brake is applied.
- Make sure that there is no one in the immediate vicinity and there are no obstructions around the machine.

Starting the Equipment

- Do not start the engine or move any of the controls if there is a warning tag attached to the controls. Check with the person who attached the tag before starting.
- Read and follow all the instruction decals.
- Before starting the engine, check that all the gear controls are in neutral position.
- Always inspect the motor before and after starting.
- Check all the safety devices. Report any defects immediately.
- Listen for unusual noises.
- Engage hydraulic controls slowly in cold weather to avoid shock loading.

Parking the Roller

- Do not park the machine on slope surface of above 9.5° . Always use wheel chocks for parking the machine on slope surface.
- Select the level and hard ground. If necessary to park on the slope, block the front of the drums on the downside of the slope.
- Apply break in an emergency conditions.

Driving Near Edges

While driving near an edge make sure to maintain $2/3$ of the drum width on the solid ground.

Note The machine's center of gravity moves outwards when steering. For example, the center of gravity moves to the right when you steer to the left.

Note Never operate machine on side slopes. The machine may roll over, even on stable ground. Always operate the machine parallel to the slope; never perpendicular.

Figure 2-1: Position of the Drum

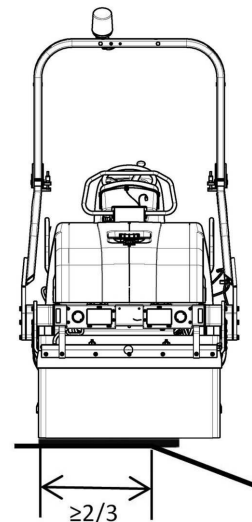

Slopes

The slope angle is measured on a hard, flat surface with the machine stationary. The steering angle was zero, the vibration was switched OFF and all tanks were full.



Always take into consideration that loose ground, steering the machine, vibration on, machine speed across the ground and raising the center of gravity can cause the machine to topple at smaller slope angles than those specified here.

Note It is recommended that ROPS (Roll Over Protective Structure) or a ROPS approved cab, is always used when driving on slopes or unsafe ground.

Figure 2-2: Operating on the Slopes

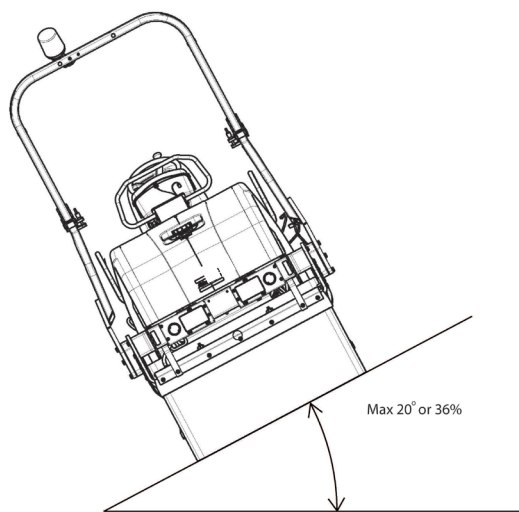

Gas Spring

- Do not expose gas spring to excessive heat or naked flames.
- Under any circumstances, gas springs must not be exposed to damaging external influences or violent handling.
- Do not try to use a gas spring that exhibits tiny dents or bends on its cylinder.

Hydraulic Maintenance Safety

The normal operating temperature of hydraulic oil is hot enough to cause serious burns. Use precautions when working on any hot fluid lines or changing filters.



Hot oil or components can burn. Avoid contact with hot oil or components. Do not allow used oil to drain into the ground. Dispose the used oil properly in accordance with the local guidelines.

Cylinder Repairs or Replacement

- When repairing cylinders, make sure to block them up to prevent dropping or rolling off the equipment.

Handling Fluids and Oil

- When draining fluids, make sure that adequate sealable containers are available and that every care is taken to prevent spillage.
- Always make sure waste fluids are disposed in an environmentally safe manner.
- Always make sure that used filters are stored in secure containers and disposed of in an environmentally safe manner.



Transporting





- Use only appropriate means of transport and lifting gear of adequate capacity.
- Fastening of loads and instructing the crane operators should be entrusted to the experienced persons only. The person giving the instructions must be within sight or sound of the operator.
- Do not attempt to load the equipment on the transport vehicle without knowledge and experience with the operation of the equipment.
- Use proper chock blocks in front and rear of the wheels of the transport vehicle when loading the equipment.
- Position the equipment on the transport vehicle centered from side to side and use proper chock blocks in front and rear of the tracks.
- Secure the equipment to the deck of the transport vehicle with adequate chains or cables and blocks to meet local regulations.
- When moving the equipment on public access roads, obey all traffic regulations and make sure that proper clearance flags, lights, and warning signs are properly displayed. Never turn corners at excessive speeds. Look in all directions before reversing the travel direction.

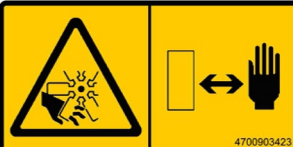

2.2 Equipment Safety Decals

Before you operate, maintain, work around, or in any other way use this roller, read and understand the safety decals and safety labels located on the roller. Follow all directions on the labels. Do not remove or deface the labels. Replace them if they become damaged or lost

Table 2-1: Decal List

Decal	Message	Location
	Warning - Crush zone	Quantity 2: Located on side of the hydraulic reservoir.
	Warning - Rotating engine components	Quantity 1: Located on rear left side of the hood.
		Quantity 1: Located on rear right side of the hood.
	Warning: Hot surfaces	Quantity 2: Located on cooler housing.
	Warning: Instruction manual	Quantity 2: Located on top of receiver and on receiver end plate.
	Warning - Risk of crushing	Quantity 2: Located on the front left and right-side fork.
	Warning: Combustible Gas	Quantity 1: Located on the carrier battery box.



Section 3: Special Instructions

3.1 Operational Limitations

Standard Lubricants and Other Recommended Oils and Fluids

Before leaving the factory, the systems and components are filled with the oils and fluids specified in the lubricant specification. These are suitable for ambient temperatures in the range 5°C to +45°C (41°F to 113°F).

Higher Ambient Temperatures

For operation of the machine at higher ambient temperatures, however maximum +50°C (122°F).

Hydraulic system - mineral oil Shell Tellus S2V68 or similar.

Lower Ambient Temperature - Freeze Risk

Make sure that the watering system is empty/drained of water (sprinkler, hoses, tank/s) or that anti-freeze has been added, to prevent the system freezing.

Temperatures

The temperature limits apply to standard versions of rollers.



High Pressure Cleaning

Do not spray water directly onto electrical components or the instrument panels.

Place a plastic bag over the fuel filler cap and secure with a rubber band. This is to avoid high pressure water entering the vent hole in the filler cap. This could cause malfunctions, such as the blocking of filters.

Do not spray with high-pressure cleaner directly onto gaskets and bearing spacings in steering hitch.



Do not spray water directly onto electrical components or the instrument panels. Place a plastic bag over the fuel filler cap and secure with a rubber band. This is to avoid high pressure water entering the vent hole in the filler cap. This could cause malfunctions, such as the blocking of filters.

Ambient Temperature Range

The ambient temperature working range between limits of 5°C and 45°C (41°F and 113°F).

Operating Conditions For Stability

Stability is affected by the orientation of the roller, surface stability (bearing strength), and wind conditions.



Travel at a safe speed relevant to surrounding conditions.

Contact the local Dynapac distributor, dealer, or service office for further information.

Note Specifications represented are calculated values at 100% efficiency.



Operator life may be endangered if the following is not complied with. Do not add attachments to the roller that intrude into the operator protective area, reduce visibility, restrict emergency exits, or add weight exceeding certification weight. See the operation manual or contact the dealer for complete inspection requirements and maintenance instructions.

Grade Limitations

Exceeding the slope or grade limitations of the roller and its configuration can cause the roller to tip over. Prior to moving the roller into position, always determine the safe operating grade of the roller.

Fire Fighting

If the machine catches fire, use an ABC-class powder fire extinguisher.

A BE-class carbon dioxide fire extinguisher can also be used.



Roll Over Protective Structure (ROPS)

! Operator life may be endangered if the following is not complied with. Do not add attachments to the roller that intrude into the operator protective area, reduce visibility, restrict emergency exits, or add weight exceeding certification weight. See the operation manual or contact the dealer for complete inspection requirements and maintenance instructions.

! Never attempt to repair a damaged ROPS structure or cab. These must be replaced with new ROPS structure or cabs.

Battery Handling

! When removing batteries, always disconnect the negative cable first.

! When fitting batteries, always connect the positive cable first.

! Dispose of old batteries in an environmentally friendly way. Batteries contain toxic lead.

! Do not use a quick-charger for charging the battery. This may shorten battery life.

Jump Starting

! Do not connect the negative cable to the negative terminal on the dead battery. A spark can ignite the oxy-hydrogen gas formed around the battery.

! Check that the battery used for jump starting has the same voltage as the dead battery.

Turn the ignition and all power consuming equipment off. Switch off the engine on the machine which is providing jump start power.

First connect the jump start battery's positive terminal (1) to the flat battery's positive terminal (2). Then connect the jump start battery's negative terminal (3) to, for example, a bolt (4) or the lifting eye on the machine with the flat battery.

Start the engine on the power providing machine. Let it run for a while. Now try to start the other machine. Disconnect the cables in the reverse order.

Figure 3-1: Jump Starting

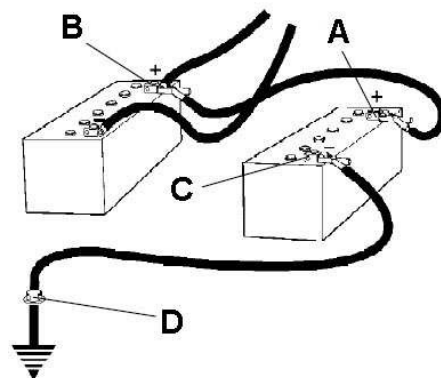

- A Battery's positive terminal one
- B Battery's positive terminal two
- C Battery's negative terminal three
- D Battery's negative terminal four



This page is intentionally left blank

Section 4: Specifications

4.1 Weight and Dimensions

Figure 4-1: Dimensions, Side View

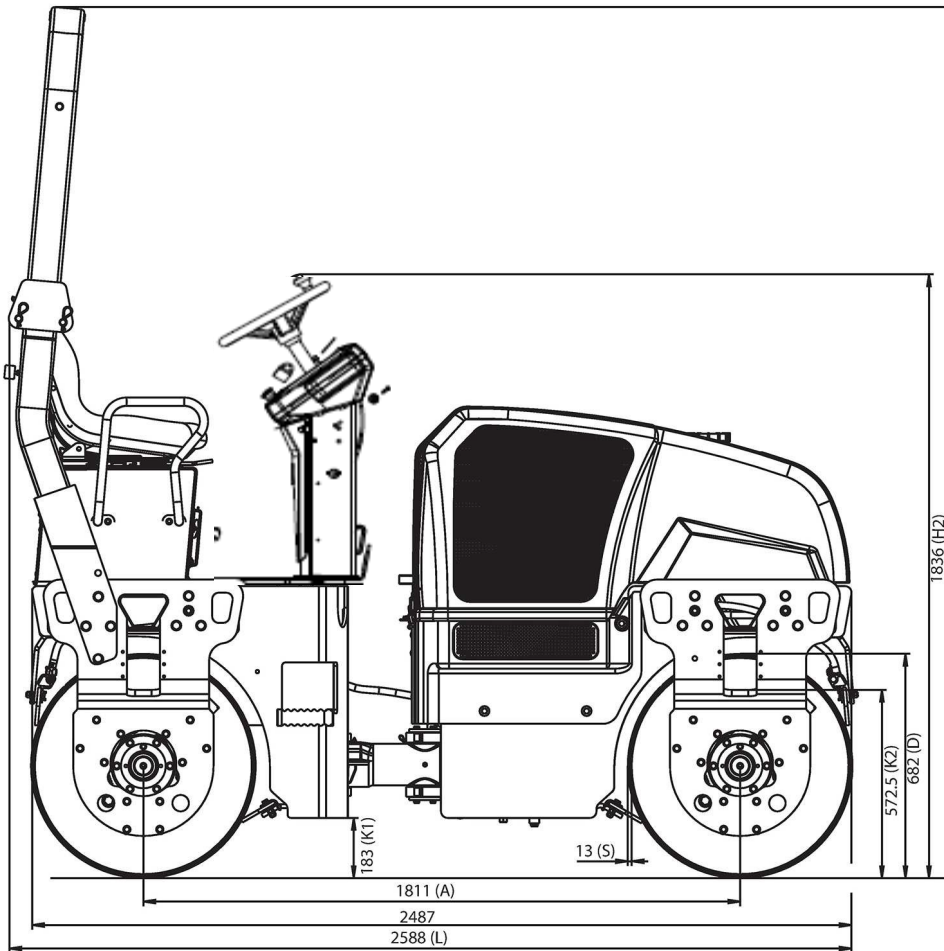

Table 4-1: Weight and Dimensions Side View

Wheelbase	1811 mm (71.3 in)
Length	2588 mm (101.89 in)
Height, with ROPS	2649 mm (104.3 in)
Height, without ROPS	1836 mm (72.3 in)
Thickness	13 mm (0.5 in)
Weight Standard equipped roller	3100 kg (6834.3 lbs)



Figure 4-2: Dimensions Top View

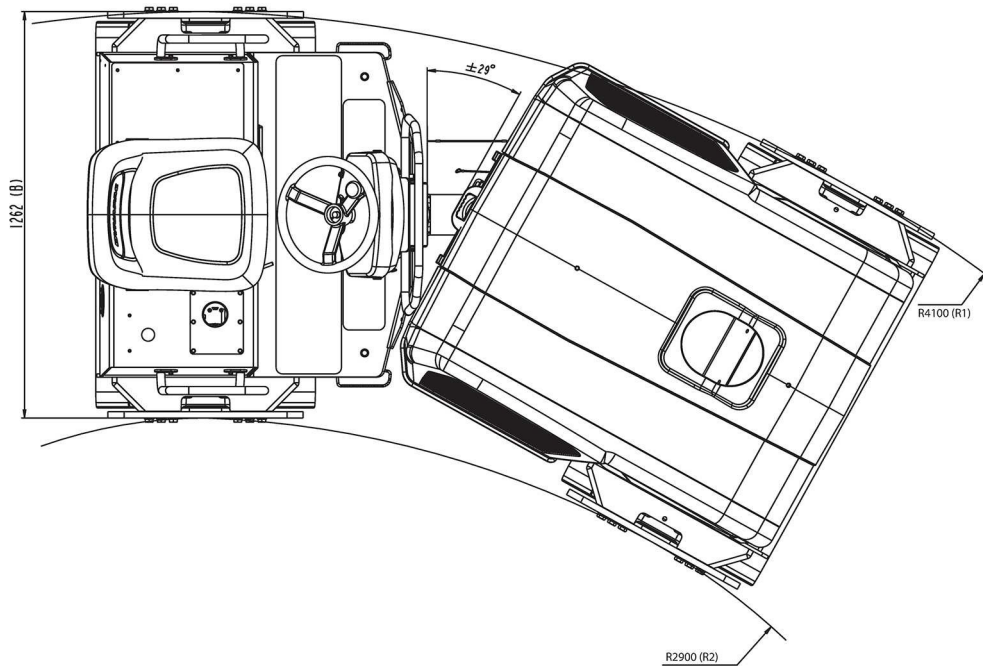

Table 4-3: Weight and Dimensions Top View

Machine width with ROPS	1447 mm (57 in)
Machine width without ROPS	1262 mm (49.7 in)
Turning radius outer	4100 mm (149.6 in)
Turning radius inner	2900 mm (114.2 in)
Drum width	1200 mm (47.2 in)

Diesel Engine

Table 4-4: Diesel Engine

Engine	Model	HP (kW) rpm
Dynapac	MDI 1895	38.5HP (28.6kW) - 2600rpm



Fluid Volume

Table 4-5: Fluid Volumes

Fuel tank	50 L (13.2 gal)
Water tank	160 L (42.2 gal)
Hydraulic tank	45 L (11.9 gal)
Drum oil	7 L (1.8 gal)
Coolant	12 L (3.17 gal) Coolant + 8 L (2.1 gal) Water

Working Capacity

Table 4-6: Working Capacity

Static linear load front	12.5 kg/cm
Static linear load rear	13.3 kg/cm
Amplitude	0.5 mm (0.01 in)
Vibration frequency	58 Hz
Centrifugal force	27 kN

Hydraulic System

Table 4-7: Hydraulic System

Opening pressure (Absolute pressure)	MPa	Bar
Drive system	35.0	350
Vibration system	21.0	210
Steering system	15.0	150
Charge pressure	2.0	20
Brake release	2.0	20



This page is intentionally left blank

Section 5: Operation Controls

5.1 Instruments and Controls

The instruments and controls section of this manual provides basic information about the operating controls, instruments, and indicators located on the consoles and around the roller.

All the operation control from the operator console located in front of operator seat under steering wheel. The slim profile and quick opening side panels provide easy access for maintenance and service.

Figure 5-1: DRA30 Console

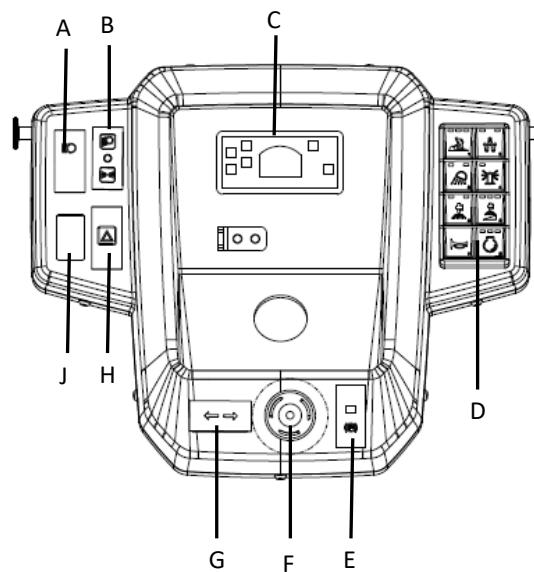

- | | | | |
|---|----------------------|---|-----------------------|
| A | High beam | F | Emergency switch |
| B | Driving lights | G | Direction indicators |
| C | Display | H | Hazard warning lights |
| D | Keypad | J | Panel plug |
| E | Parking brake On/Off | | |



Functional Description – Keypad

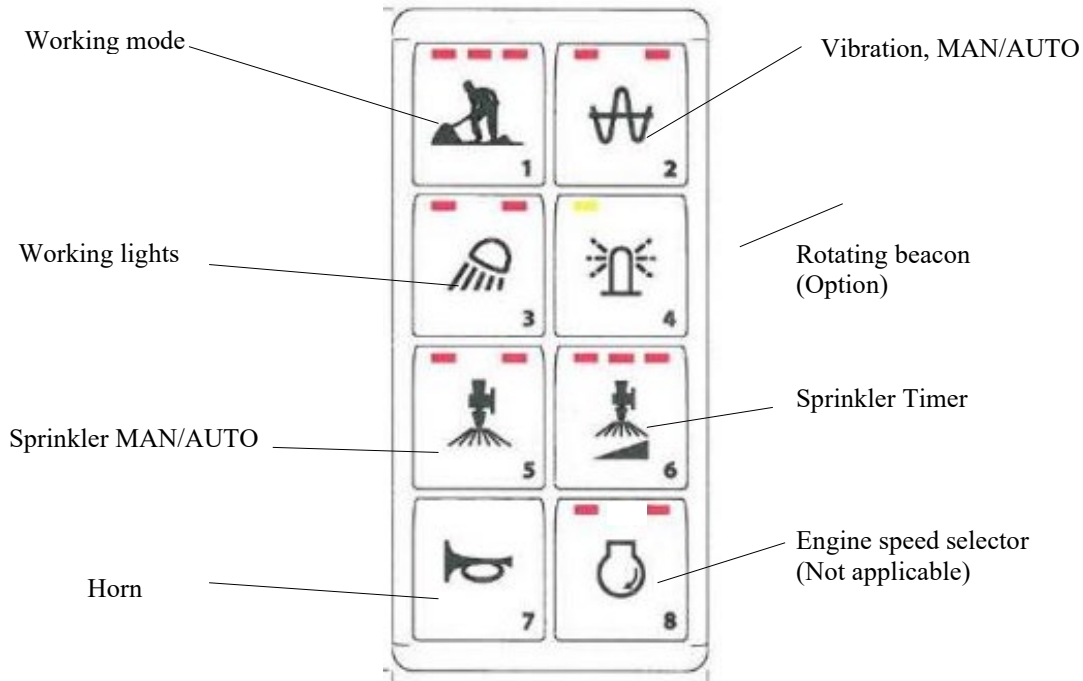

Symbol	Designation	Function	LED	LED color
	Work mode	LED OFF → Transport mode		-
		LED LEFT → Working mode, vibration		Red
	Vibration MAN/Auto	LED LEFT → MAN		Red
		LED RIGHT → AUTO		
	Working lights	Turns on the working lights of canopy.		
		LED OFF		-
		LED LEFT → Working lights, ON		Red
	Sprinkler Manual/Auto	LED LEFT → Sprinkler manual		Red
		LED RIGHT → Sprinkler auto		Red
	Sprinkler Timer	LED LEFT → Sprinkler spray low		Red
		LED CENTER → Sprinkler spray medium		Red
		LED RIGHT → Sprinkler spray high		Red
	Engine speed selector	Not Applicable this machine		
	Rotating beacon (Option)	LED LEFT → Beacon ON		Yellow



Starter Switch

The starter switch starts and stops the engine. There are three positions in the starter switch, they are:

- OFF position: In this position all the electric systems and the engine are switched off, and the key can be removed.
- ON position: In this position, Engine is on run mode. Charging circuit and lamp circuit are energized.
- Start position: In this position, the engine cranks. Make sure to allow the switch to on position until the engine is started.

Figure 5-2: Starter Switch

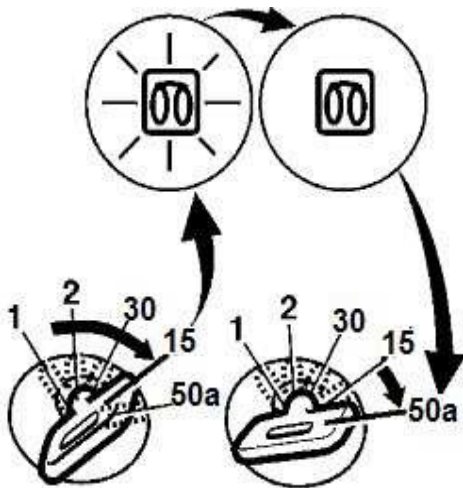

- | | | |
|----------------|------|--|
| 1 Off position | 30 | Start position to supply power to the instruments and controls |
| 2 On position | 15 | Hold position |
| | 50 a | Starter motor activation. |

Throttle Lever

The throttle control regulates the speed of the engine. In forward position, the engine idles and in the backward position, the engine runs with a full speed.

Figure 5-3: Throttle Control

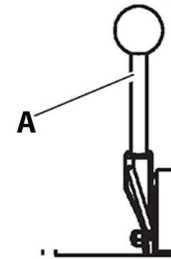

A Throttle lever

Work/Transport mode

The 1st number button is used for work or transport mode selection. Press the button to turn on the work mode with Red illumination in button and press again to turn On the transport mode.

Figure 5-4: Vibration On/Off Switch



A Work/Transport mode



Emergency Stop

The emergency button is used to stop the engine in an emergency situation which it cannot be shut off in an usual manner. It switches off the engine and activates the brakes. The emergency stop aborts the entire control operation in a quicker way for the safety of the personnel.

Figure 5-5: Emergency Stop

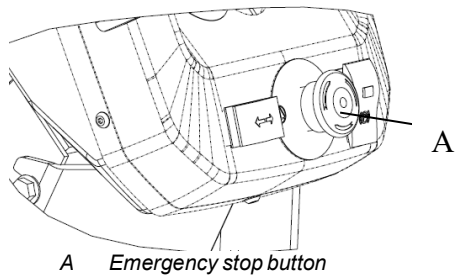

Sprinkler Switch

Figure 5-7: Sprinkler Manual/Auto

A. Sprinkler Manual/Auto

B. Sprinkler timer

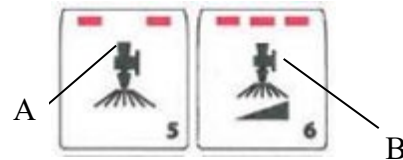

Sprinkler timer will work only when AUTO mode Selected.

Forward/Neutral (FNR) Lever

Direction of travel and speed of the roller is regulated with the forward/reverse lever. The machine speed increases or decreases in proportion to the position of the lever.

Figure 5-6: FNR Lever

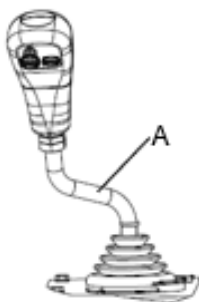

A FNR lever

Seat Buzzer

Seat buzzer beeps if the operator is not seated during the operation of the roller and it continues to beep until the operator is seated. If the buzzer beeps for long the brakes are activated and engine is forced to stop.



Horn Button

The horn button is located on the switch assembly.

Press the button to activate the horn.

Figure 5-8: Horn Switch



Vibration Activation Switch

In first press, Vibration MAN mode is selected with RED illumination in left side & in second press, Vibration AUTO mode is selected with RED illumination in right side.

Figure 5-9: Vibration Activation Switch



Drum Selector Switch

Depending on the Drum selector, the vibration is activated in the following places

Right side button	Activates vibration for front drum.
Left side button	Activates vibration for rear drum.

Note – Only front Drum will not activate, for both Drum activation first need to activate Rear Drum then activate Front Drum.

Figure 5-10: Drum Selector Switch

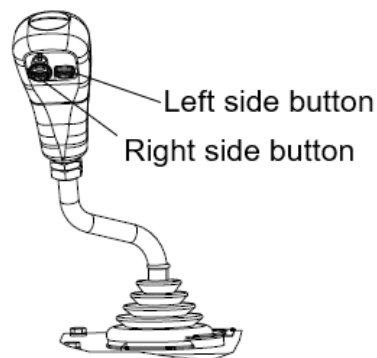

Fuse Box

The fuse box is located on the control column which contains the fuses for the electrical system. Fuses protect the electrical components from damage because of a short circuit. Refer to electrical system for the description and functions of the fuses.



Driving Lights Switch

Push up, to switch on the driving lights and depress to switch on the parking lights. In intermediate position the lights are switched off.

Figure 5-11: Driving Lights

- A *Push up Position*
- B *Intermediate position*
- C *Depressed position*

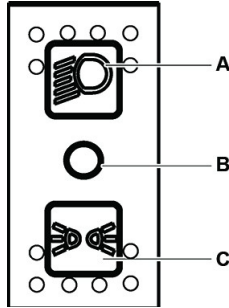

Hazard Warning Lights Switch

Hazard warning lights are primarily used to warn other vehicles that there is a problem either with the roller, or there is a hazard in front of roller causing the operator to reduce speed quickly.

Figure 5-13: Hazard Warning Lights

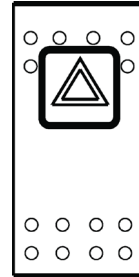

Depress the switch to switch on the hazard warning lights.

Rotating Beacon Switch (Optional)

Rotating beacon lighting is generally used to warn the approaching machine of potential hazards, such as machine that is stopped or moving slower than the rate of the traffic.

Depress the switch to switch on the rotating beacon.

Figure 5-14: Rotating Beacon Switch



Working Lights Switch (Optional)

Depress the switch to switch on the working lights.

Figure 5-12: Working Lights



Direction Indicator Switch

The direction indicators are blinking lamps mounted near the left and right, front and rear corners of the roller. Depress the switch either left or right, to on the left or right indicators. In the intermediate position the function is shut off.

Figure 5-15: Directional Indicator Lights

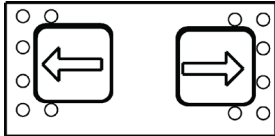

Parking Brake On/Off Switch

The parking brake On/Off switch is used to activate the parking brake.

Note Parking brake must be activated while starting the engine. Always activate the parking brake when the machine is stationary on a sloping surface.

Figure 5-16: Parking brake On/Off Switch

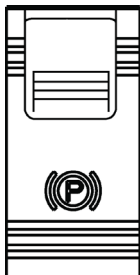

Control Panel

Figure 5-17: Control Panel

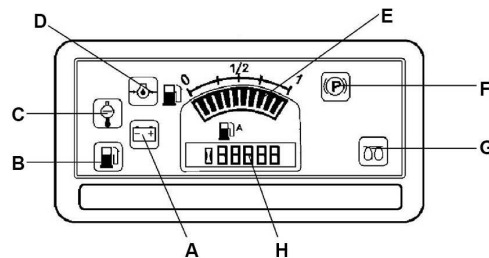





<i>A</i>	<i>Battery/charging</i>	<i>E</i>	<i>Fuel level</i>
<i>B</i>	<i>Low fuel level</i>	<i>F</i>	<i>Parking brake lamp</i>
<i>C</i>	<i>Engine water temperature</i>	<i>G</i>	<i>Glow plug</i>
<i>D</i>	<i>Oil pressure, engine</i>	<i>H</i>	<i>Hour meter</i>

Control Panel Warnings Symbols

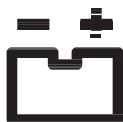
Warning lights comes on when the starter switch is turned to the on position and should goes off once the engine has started. If the lights comes on when the engine is running indicates a faulty condition.

Table 5-1: Warning Lights



Designation	Function	Description
	Battery charging indicator lamp.	If light does not illuminate when ignition is switched on, illuminates after engine is started, the battery is not charging. Contact maintenance personnel if the lamp comes on during trammng.
	Diesel engine lubricating oil pressure indicator lamp.	If the pressure is too low, the lamp comes on and the parking brake is applied. In this event, switch the engine off immediately and rectify the cause. Contact maintenance personnel.
	Engine temperature signal lamp.	The lamp comes on when the temperature is too high. The engine must be switched off immediately and contact the maintenance personnel if the lamp comes on during trammng.
	Low fuel level indicator.	This lamp comes on if the oil level is low in the fuel tank.



Control Panel Notification Symbols

Notifications are displayed when the starter switch is turned to the on position and notifies that corresponding systems are operating.

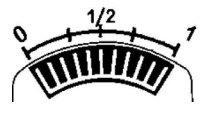
Table 5-2: Notification Lights

Designation	Function	Description
	Parking brake indicator lamp	The light illuminates when the parking brake is activated.
	The fuel level gauge	The fuel level gauge monitors the level of fuel in the fuel tanks of the roller. The fuel gauge is shown in increments of zero, 1/4, 1/2, 3/4, and one. When the indicator needle shows 1/4, the fuel tank should be filled.
	Hour meter	It displays the number of hours the engine has run.



This page is intentionally left blank

Section 6: Inspections and Operations

6.1 General Information

Note If you are not experienced with the roller controls read and understand section 5 - Operation Controls.

The following operational hints should be observed:

- Do not speed the engine when it is cold.
- Do not lubricate the roller while the engine is running.
- Always perform safety checks prior to starting the roller.
- Never stop the roller on a slope or surface that is liable to collapse.
- Never stop the roller against a high wall that is liable to collapse or cause a crushing risk.
- Before starting the engine, make sure all operator controls are either in off or neutral positions and that the parking brake is applied.
- Always sound the horn before moving the roller in either direction to alert personnel and to allow sufficient time before putting the roller in motion.
- Always judge when driving on unstable surfaces where there may be a risk of overturning or when loading onto a transporter where there is a risk of overturning. Always use a spotter.

General Checks

General checks should be made for any wear and tear on the roller. Check for broken or cracked welds, loose or missing bolts, broken or inoperative gauges, or any other irregularities which could lead to more costly breakdowns.

Check all bolted assemblies for tightness. Inspect the entire roller for any loose, worn, or missing parts and replace them as needed. Inspect fluid lines, hoses, filler openings, drain plugs, pressure caps, tires, tower cables, hoist wire cables, muffler, engine, safety shrouds, and the area under the roller for signs of leakage.

Note Frequently walk around the roller and inspect for leaks, loose or missing parts, damaged parts or parts out of adjustment. Perform all recommended daily maintenance.

Operator Areas

- Keep operator areas, mirrors, and all lights clean. Check for all lights function.
- Make sure the operator areas, steps, and grab rails are clean. Oil, grease, snow, ice, or mud in these areas can be slippery. Clean the boots of excess mud before getting on the roller.



Check Engine Oil Level



- *Hot oil and hot components can cause personal injury. Do not allow hot oil or hot components to contact the skin.*
- *Never operate the engine with the oil level below the low (L) mark or above the high (H) mark.*

Note *Wait at least five minutes after shutting off the engine to check the oil level. This allows time for the oil to drain into the oil pan.*

1. Level the roller. The roller must be level when checking the oil level to make sure the measurement is correct.
2. Shut off the engine.
3. Check the engine oil level by viewing the engine dipstick.
4. If the oil level is low, add oil through the fill cap

Figure 6-1: Engine Oil Dipstick

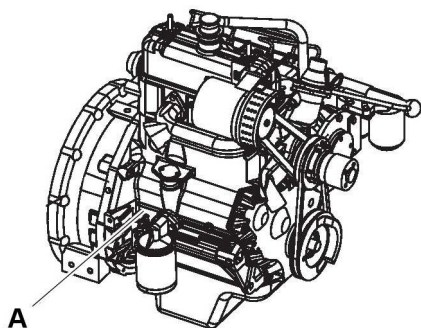

A Engine oil dipstick

Check Engine Coolant Level

Check the coolant level through transparent plastic of expansion tank. Fill the cooling system when coolant is empty. With the engine cold, top off with premixed coolant of the desired freeze protection concentration. Add coolant through the pressure cap neck of the surge tank.



Always shut off the engine and allow to cool before removing the radiator cap. Remove cap slowly to relieve pressure. Avoid contact with steam or escaping fluid.



Removing the radiator cap on a hot radiator can cause scalding coolant to spray out and burn the body badly. If the engine has been in operation within the previous 30 minutes, be very careful in removing the radiator cap. Protect face, hands, and arms against escaping fluid and steam by covering the cap with a large, thick rag. If you see any steam or coolant escaping, do not try to remove it until the radiator cools down. If nothing is escaping, remove the cap very slowly and be careful. Be ready to step away if any steam or coolant begins to escape. Inhibitor contains alkali. Avoid contact with skin and eyes.



Engine coolant must be properly maintained to protect against engine damage. Coolant must be tested at regular intervals to make sure it can provide adequate protection against freezing, boiling, and corrosion. It is the owner's responsibility to know the type of coolant used and to maintain it properly.

If coolant must be added, use a reliable brand of permanent antifreeze in a 60-40 mixture. It must be used year round in all climates. Refer to instructions in **7.5 Maintenance as Required** for the correct procedures.



Check the Fuel Level



Fuel is flammable and may cause serious injury or death. Shut off the engine, extinguish all open flames, and do not smoke while filling the tank. Always wipe up any spilled fuel immediately

Check fuel level on the fuel level gauge on the machine dashboard. Refill the tank when the indicator needle moves to below 1/4 tank. Refer to the maintenance procedures in **section 7 - Maintenance**. Select the proper grade of fuel oil in accordance with the instructions given in the *Lubrication Table* in **section 7 - Maintenance**.

Maintain fuel tank(s) at a high level to minimize water condensation inside the tank(s). This is best accomplished by filling the fuel tanks at the end of each shift or day. Check the fuel tank for possible leaks. Because of the potential fire hazard, leaks must be corrected as soon as they are spotted.

1. Check the fuel level by reading the fuel level gauge.
2. Do not allow the fuel tank to completely empty, otherwise the entire fuel system will require bleeding.
3. If the fuel level is low, add clean, filtered fuel.
4. Fill tank with the correct grade of fuel. Refer to *Lubrication Table* for more fuel details.

Check Batteries



Batteries contain an acid and can cause injury. Battery fumes can ignite and explode. Do not smoke when observing battery fluid level. Skin and eye contact with battery fluid can cause injury. Avoid skin and eye contact with battery fluid. If contact occurs, flush area immediately with water.

Check the battery posts and cables for corrosion. Check and keep the electrolyte levels above the battery plates or to the bottom of the fill holes. Refer to **section 7 - Maintenance** for the correct procedures.

Verify the Controls

Before starting the roller, check that the warning lights, backup alarm, horn and emergency stop controls are functioning properly. This inspection should be performed before each shift and at every start-up.



If any controls, instruments or devices do not function correctly, report the defects to the proper personnel. Defects must be corrected before starting and operating the roller.



6.2 Before Starting the Engine

Remember to carry out daily maintenance before starting the engine.

Refer to **section 7 - Maintenance**.

Consider the following points before starting the engine:

1. Before starting the engine, check inside, outside, and underneath the roller for people or obstructions.
2. Turn the battery disconnecter key to switched on position which is located on the right side of the operator compartment. This supplies the roller with the power.

Figure 6-2: Battery Disconnecter

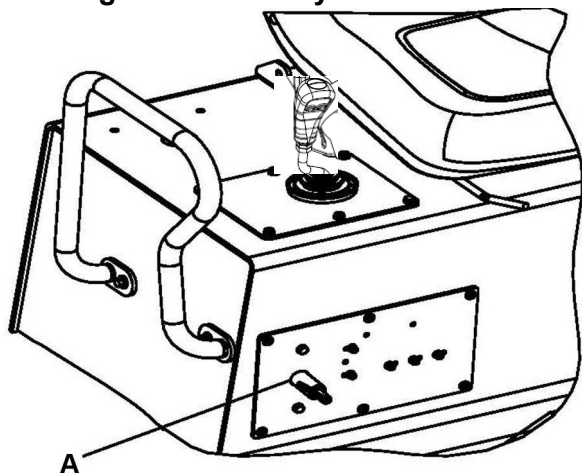

A Battery disconnecter

3. Check for warnings on the controls.
4. Start the engine from the operator position only.
5. Avoid leaving the controls with the engine running. Never leave the operator platform while the roller is running.



If any controls, instruments, or devices do not function correctly report the defects to the proper personnel. Defects must be corrected before starting and operating the roller.

Seat (Standard) Adjustment

Adjust the operator's seat to the comfortable position so that the controls are within easy reach.

The seat is adjusted in the following way:

- **Length adjustment:** Pull the lever and move the seat forward or back.

Figure 6-3: Seat Adjustments

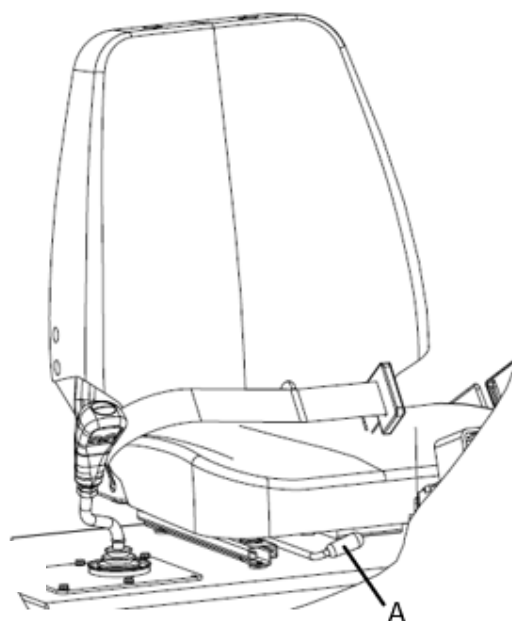

A Length adjustment



Check the Instruments and Lamps

Note Make sure that the emergency stop is pulled out and the parking brake is activated. If the forward/reverse lever is in neutral, the automatic brake function is engaged.

1. Turn the switch to on position.
2. Check that the warning lamps in the warning panel come on.
3. Set the sprinkler switch to the operating position and check that the system is functioning.

Interlock

The roller is equipped with interlock. The diesel engine switches off after 10 seconds, if the operator gets off the seat during tramming. If the operator is not seated during tramming a buzzer goes on unless the parking brake is activated.

Note If the diesel engine is switched off, then wait for 15 seconds to restart it. Turning the ignition key to on position will not restart the engine during this period.



6.3 Operating the Roller

Operation

1. Before the roller start-up, a pre-operational general inspection of the roller must be performed in accordance with those instructions previously mentioned and, in the instructions, found in **section 7 - Maintenance**.
2. Make sure all operator console controls are either off or in the neutral position and all control console gauges read zero.

Figure 6-4: Operator Consoles

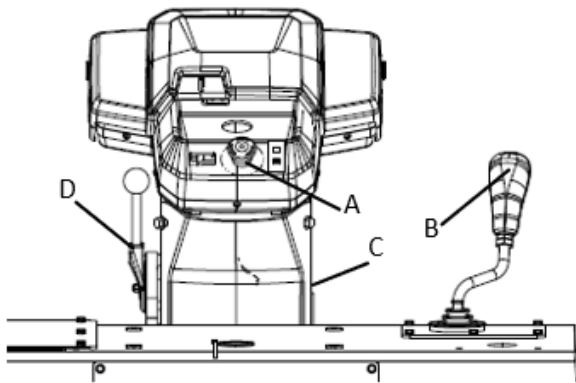

- | | |
|------------------|-------------------|
| A Emergency stop | C Ignition switch |
| B FNR lever | D Throttle lever |

3. Make sure the emergency stop button is not activated.
4. The FNR must be in neutral position.
5. Parking brake switch must be in engaged condition.

6. Make sure the throttle control is turned to low position.

Figure 6-5: Throttle control

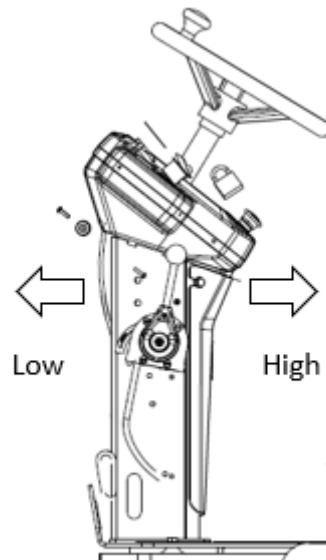

7. Set the vibration switch for Front or both drum selection on forward/reverse lever. The operator must activate the work mode in key pad.

Figure 6-6: Vibration Rear/Both drum selection Switches

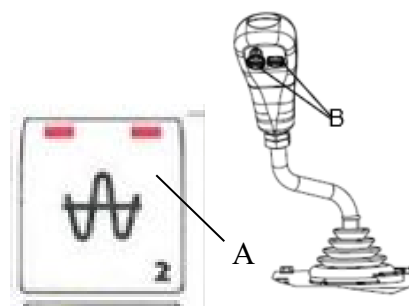

- | |
|-------------------------------|
| A Vibration Activation switch |
| B Drum Selection switch |



Note As a general rule, do not operate the starter motor more than 30 seconds at a time without pausing to allow the starter motor to cool for at least 2 minutes. Overheating caused by excessive cranking will seriously damage the starter motor.

8. Turn the ignition switch on, check all the warning lamps and then crank the engine.
9. Allow the engine to warm up at idle speed for few minutes. Warm up time should be extended when extremely low ambient conditions (cold weather) occur or when battery power is depleted during initial start-up.
10. Check the engine air cleaner indicator gauge to determine if the elements require servicing.
11. Make sure the parking brake is released and the parking lights goes off.

Figure 6-7: Parking Brake

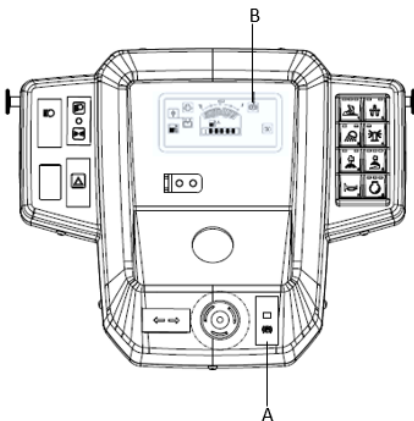

- A Parking brake button
B Parking brake indicator

Vibration on One Drum

1. Activate the vibration selector switch to select vibration with the rear drum only, or with two drums.
2. Vibration selector is activated through the switch in the FNR Lever.
3. In the lower position the vibration is activated on both drums.
4. In the upper position the vibration on the front drum is switched off.

Braking

Normal Braking

1. Turn the vibration off by pressing the vibration control button on the forward/reverse lever.
2. Set the forward/reverse control to the neutral position and apply brake to stop the roller.

Note In cold climatic condition braking distances can be longer than the normal distance.

Note Never leave the operator platform without activating the parking brake.

Emergency Braking

To hold the machine in a stopped position (parked), there is a mechanical parking brake on each drum drive motor. The mechanical parking brakes are spring-activated and hydraulically released type brakes.

1. In case of emergency, push in the emergency stop knob, hold the steering wheel firmly and be prepared for a sudden stop. The diesel engine stops.
2. After emergency braking, reset the forward/reverse lever to neutral position, pull out the emergency stop and activate the parking brake. Restart the engine.



Switching Off

1. Press the vibration control button to off position.
2. Set the forward/reverse control to the neutral position.
3. Turn the throttle control to forward position and allow the engine to idle for a few minutes to cool.
4. Press the parking brake button to activate the parking brake. Always activate the parking brake before leaving the machine.

Note If the machine must be parked on a sloping surface, chock the drums with wedges to prevent any movement.

5. Check instruments and warning lamps to see if any faults are indicated. Switch off all lights and other electrical functions.
6. Turn the starter switch to the off position to stop the engine.
7. Switch off the battery disconnecter and remove the key.



6.4 Lifting and Handling

Locking the Articulation

Note Lock the steering joint, before lifting the roller.

1. Turn the steering wheel to the straight-ahead position.
2. Switch off the machine and activate the parking brake.
3. Pull down the galvanized lock bar from its holder and place it from underneath in the hole on the lower steering joint bracket.
4. Press the bar until the upper end is visible in the hole on the upper steering joint bracket.
5. Secure the bar with the lock pin.

Note Remember to refit the lock bar in its holder after operation.

Figure 6-8: Locking the articulation

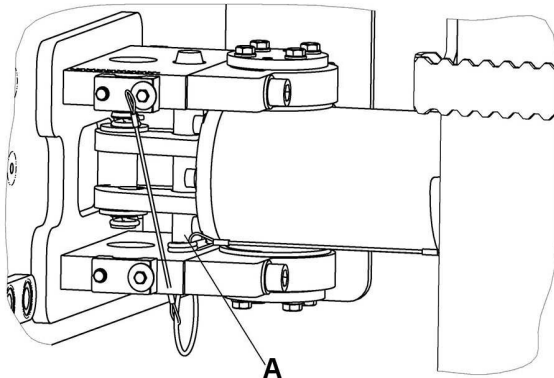

A Lock bar

Lifting the Roller

- Use a crane/forklift to lift the equipment.
- Pay attention when lifting and balancing the equipment.
- Seek a person to guide the way when lifting and moving the equipment.
- An experienced crane/forklift driver should drive the crane/forklift.
- When lifting, add a pad at the joint of steel cable of the crane and the hook hole and secure the hole.

*Note The weight of the machine is shown on the lifting plate.
Refer to **section 4 - Specifications.***

Figure 6-9: Lifting the roller

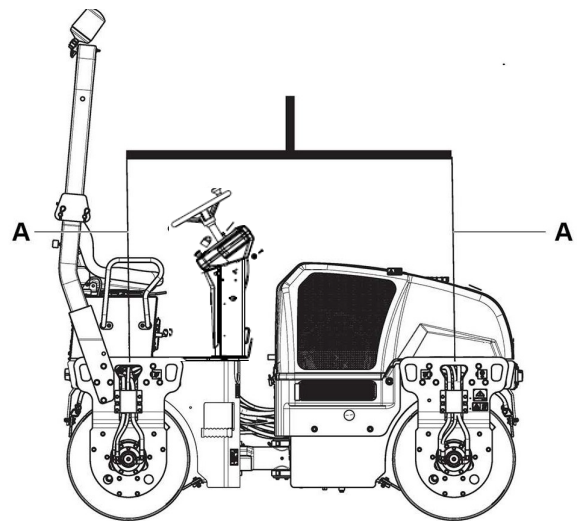

A Lifting plate





6.5 Towing the Roller

Towing Information

Proper equipment must be used to prevent damage to the vehicle and the roller during any tow. Follow the state and local laws applying to vehicles.

If the vehicle is to be towed by a wrecker, use only equipment designed for this purpose following the instructions of the wrecker manufacturer. A safety chain system must be used.

 *Personal injury or death could result when towing a disabled roller incorrectly.*

 *Block the drums of the roller to prevent movement before releasing the emergency brake system or the disc brake in each drive motor must be disengaged mechanically, before the roller can be towed. The roller can roll free if drum is not blocked.*

 *Follow the recommendations below to properly perform the towing procedure.*

 *Make sure to block the drums of the roller and reapply the emergency brake system before disconnecting from the towing vehicle.*

Note Maximum towing speed is 2 mph (3 Kmph).

Towing

The roller can be moved up to 300 meters (1,000 ft) using the instructions below.

Note Chock the drum to prevent the roller from moving when the brakes are hydraulically disengaged.

Release the Brakes

The disc brake in each drive motor must be disengaged mechanically, according to the following instructions, before the roller can be towed.

1. Remove the center plug using a screwdriver.
2. Screw off the brake tool from its threaded fixing hole. Then fix the brake tool in the center hole by tightening the screw until it bottoms in the hole.
3. Tighten the nut against the brake tool until it stops, indicating that the brakes are now disengaged.

Figure 6-10: Left Side of Drum

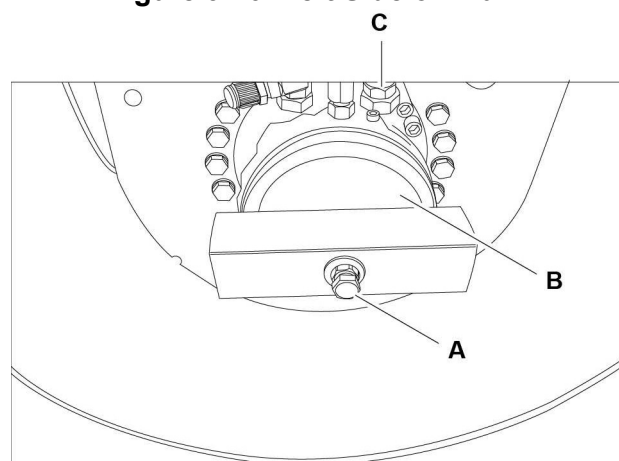

A Brake tool

C Disengagement nut

B Fastening screw

Note Make sure to secure the steering wheel to maintain a straight-ahead position.



4. Slightly tap the plunger inside using a mallet.

Figure 6-11: Plunger

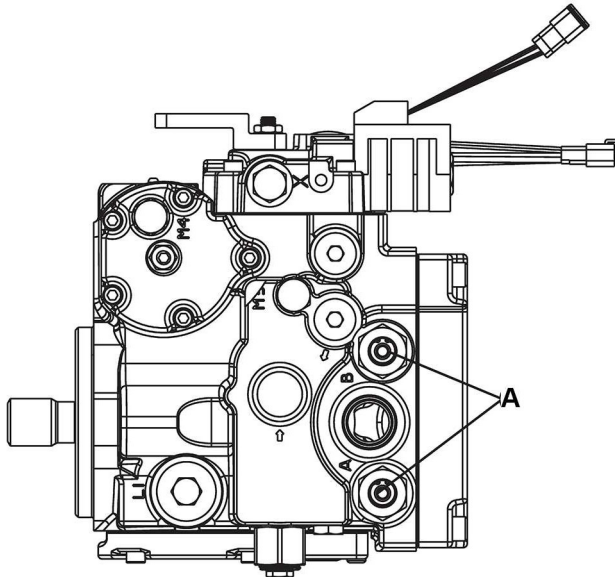

A Pluger

Engaging the Brakes

1. Screw out the nut again after towing.
2. Screw off the brake tool and fit it back into its fixing holes
3. When machine is started, propulsion pump plunger will automatically come out.
4. Refit the center plug to counteract the information of rust inside the threaded hole.
5. When towing/retrieving a machine, the towing device must be connected to both lifting holes. The pulling force shall act longitudinally on the machine. Maximum total pulling force 130 kN (29225 lbf).

Figure 6-12: Towing

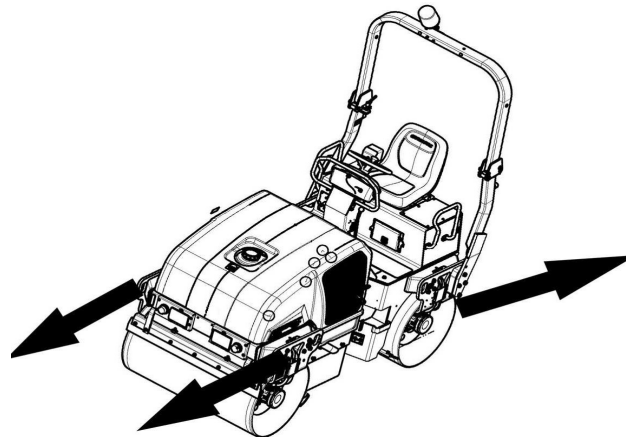

6.6 Transporting the Roller

Transportation Procedures

Safety Precautions

Before moving the roller on public roads, check for instructions and information with respect to traffic regulations regarding construction machinery.

The roller must be driven and transported only in accordance with the operating instructions.

1. When driving the roller, observe the prescribed transport position, admissible speed, and itinerary.
2. Do not attempt to drive unless knowledgeable and experienced.
3. Always know the overall height, weight, width, and length of the roller. Make sure there is sufficient clearance when crossing underpasses, bridges, and tunnels or when passing under overhead lines.
4. When moving the roller on public access roads, obey all traffic regulations and make sure that proper clearance flags, lights, and warning signs, including the slow-moving vehicle emblem, are properly displayed. Know your approximate stopping distance at any given speed. Never turn corners at excessive speeds. Look in all directions before reversing the direction of travel.

Operator Checklist

- Make sure to know the vehicle and its equipment and how to use it safely.
- See that mirrors, and lights are clean and unobstructed.
- Check for fluid leaks.
- Check lights and reflectors.
- Check oil and coolant levels.

Start Up

1. Before starting the engine, check inside, outside, and underneath the roller for people or obstructions.
2. Always horn before starting the roller to alert everyone in the area.
3. Check all the gauges (including fuel).
4. Check for excessive noise or vibration.

Before Driving

1. Fasten the seat belts.
2. Adjust each mirror so that the side of the vehicle is visible in the side of the mirror closest to the vehicle. This helps you determine the relation to objects seen in the mirror.
3. Release the parking brake.



Securing for Loading

Figure 6-13: Securing for Loading

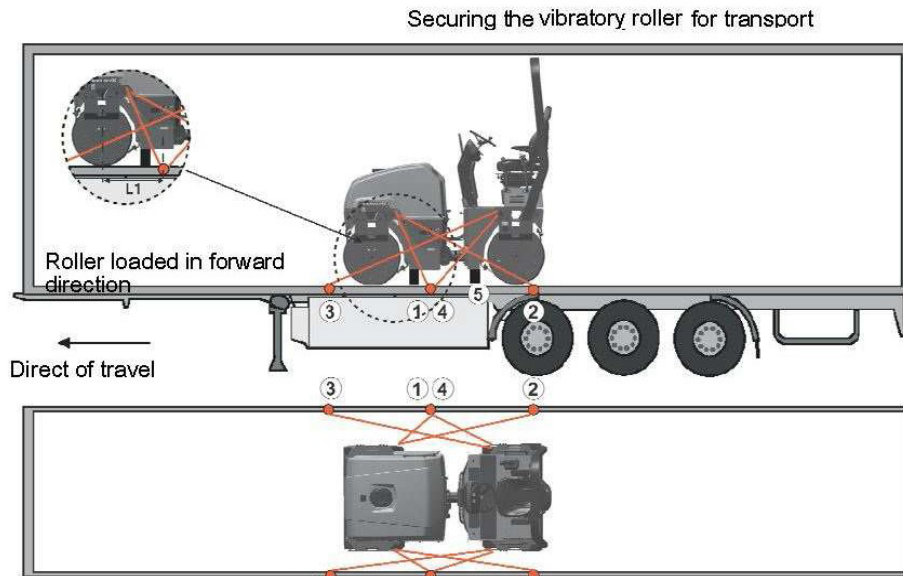

- 1,2 Double lashings, i.e. one lashing with two parts secured to two different lashing mounts.
- 3,4 symmetrically located on the right and left sides.
- 5 rubbers

Table 6-1: Lashings' Permitted Distance

The lashings' permitted distance interval in meters		
(1 - 4: Double lashings, LC at least 1.7 tonnes (1700 daN), STF 300 kg (300daN))		
Double L ₁ - L ₂	Double L ₃ - L ₄	
0,6 - 3,0	0,1 - 3,0	

The distance L₁ above is between points D and E. D is the projected point directly at right angles laterally in relation to the edge of the platform from the lashing mount C on the roller. E is the lashing mount at the edge of the platform. L₂ – L₃ have a corresponding relationship.



6.7 Special Conditions

Cold Weather Conditions

- Refer to **section 7 - 7.3 Refill Capacities/ Lubricants** in the maintenance section for information regarding cold weather lubricants, hydraulic fluids, coolants, fuel, and the like.
- Use winter grade diesel fuel for operation at sub-zero temperatures.
- Be extremely careful when using cold weather starting aids. Starting aids are very flammable and should only be used if needed.
- Remove batteries and store in a warm area to about 68 °F (20 °C).

Hot Weather Conditions

- Monitor temperature gauges.
- Keep cooling fins on radiator and oil cooler clean and free of accumulated dirt.

High Altitude Conditions

- Be aware that engine power will be reduced.
- Keep cooling fins on radiator and oil cooler clean and free of accumulated dirt.

Long-term Parking

- Observe the following when storing the roller for short periods of time.
- Remove the battery/batteries from the machine, clean and charge once a month.
- Cover the air cleaner (Refer **section 7 - Maintenance**) or its opening with plastic or tape.
- Also cover the exhaust pipe opening. This is to avoid moisture entering the engine.
- Fill the fuel tank completely full to prevent condensation.
- Fill the hydraulic reservoir to the uppermost level mark.
- Empty the water tank completely to avoid fouling.

- Lubricate the steering joint bearings and both bearings on the steering cylinder with grease. Grease the steering cylinder piston with conservation grease. Grease the hinges on the doors to the engine compartment and the cab. Grease both ends of the forward/reverse control (bright parts).
- Change all lubricants and fluids that may have deteriorated with use.
- Replace and secure all weatherproof covers.

Figure 6-14: Long Term Parking

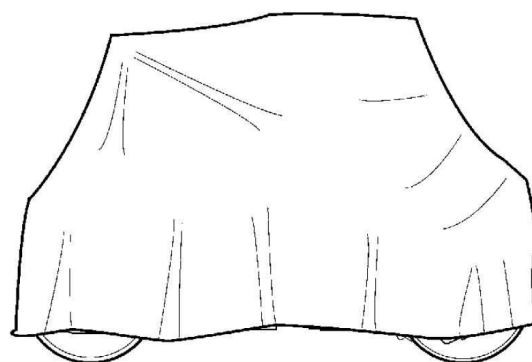

Section 7: Maintenance

7.1 General Information

Safety should be the main concern for anyone working on or around the roller. Do not perform any function that could put someone in danger.

Always wear proper safety gear while working on or around the roller. This includes an approved hard hat, safety glasses, steel toe shoes, gloves, respirator, and ear protection. Do not wear loose fitting clothing that can get caught in rotating components.

Note If not experienced with the roller controls and instruments, read and understand Operation Controls.

The following operational hints are observed:

- Do not speed the engine when it is cold.
- Always chock the drum if there is a possibility of uncontrolled movement.
- Do not lubricate the roller while the engine is running.
- Always perform safety checks prior to starting and using the roller.
- Always operate the roller at the full engine power.
- Never propel or stop the roller on a slope or surface that could possibly collapse.
- Never stop the roller against a high wall that could possibly collapse or cause a crushing risk.
- Before starting the engine all the controls are in the off or neutral position on the operator control panel.
- Always sound the attention horn before moving the roller in either direction to alert personnel and allow sufficient time before putting the roller in motion.



7.2 Maintenance Schedule

Maintenance Schedule Information

The maintenance schedule shows those items requiring regular service and the interval at which they are performed. A regular service program is geared to the items listed under each interval. These intervals are based on average operating conditions. Before each consecutive interval is performed, all of the maintenance requirements from the previous interval must also be performed.

Note In the event of extremely severe, dusty, or wet operating conditions, more frequent maintenance than specified is necessary.

Table 7-1: Maintenance Daily/Every 8 Hours

Description	Action	Lubrication
Engine oil	Check	
Outer air cleaner element	Check	
Radiator coolant	Check	
Hydraulic Oil	Check	
Greasing	Grease	See lubrication chart

Table 7-2: Maintenance at First 50 Hours

Description	Action	Lubrication
Engine oil filter element	Change	See engine manual
Engine oil	Change	See engine manual
Fuel filter element	Change	See engine manual
Mud filter	Change	See engine manual
Hydraulic oil filter	Change	

Table 7-3: Maintenance at 50 Hours or Weekly

Description	Action	Lubrication
Alternator belt	Check	
Water separator	Drain	
AVM Bolts	Check	

Table 7-4: Maintenance at 250 Hours/750 Hours/Three Months

Description	Action	Lubrication
Engine Oil filter element	Change	See engine manual
Engine oil	Change	See engine manual
Fuel filter element	Change	See engine manual
Mud filter	Change	See engine manual
ROC cleaning	Clean	
Fuel pipe and clamps	Check	
Intake air line	Check	
Drum oil	Check	
Battery	Check	

Table 7-5: Maintenance at 500 Hours/Six Months

Description	Action	Lubrication
Engine oil filter element	Change	See engine manual
Engine Oil	Change	See engine manual
Fuel filter element	Change	See engine manual
Mud filter & Water Separator	Change	See engine manual
Primary air cleaner element	Change	
Secondary air cleaner element	Change	
Alternator belt	Check	See engine manual
Fan belt	Check	See engine manual
ROC Cleaning	Clean	
Fuel pipe and clamps	Check	
Intake air line	Check	



Table 7-6: Maintenance at 1,000 Hours/One Year

Description	Action	Lubrication
Engine oil filter element	Change	See engine manual
Engine oil	Change	See engine manual
Fuel filter element	Change	See engine manual
Mud filter & Water separator	Change	See engine manual
Alternator belt	Check	See engine manual
Fan belt	Check	See engine manual
Valve cover gasket	Change	See engine manual
Radiator coolant	Change	
ROC cleaning	Clean	
Fuel pipe and clamps	Check	See engine manual
Intake air line	Check	
Valve clearance	Check	See engine manual
Hydraulic oil filter	Change	
Drum oil	Change	

Table 7-7: Maintenance at 2,000 Hours/Two Years

Description	Action	Lubrication
Engine oil filter element	Change	See engine manual
Engine oil	Change	See engine manual
Fuel filter element	Change	See engine manual
Mud filter & Water Separator	Change	
Outer air cleaner element	Change	
Inner Air cleaner element	Change	
Alternator belt	Check	See engine manual
Fan belt	Check	See engine manual
Valve cover gasket	Change	See engine manual
Radiator coolant	Change	
ROC cleaning	Clean	
Fuel pipe and clamps	Check	See engine manual
Intake air line	Check	
Valve clearance	Check	See engine manual



Description	Action	Lubrication
Hydraulic oil	Change	
Hydraulic oil filter	Change	
Drum oil	Change	
Drum AVM	Change	



7.3 Refill Capacities/Lubricants

General Information

Lubrication is an essential part of preventive maintenance, affecting to a great extent the useful life of the unit. Periodic lubrication of the moving parts reduces to a minimum the possibility of the mechanical failures.

The lubrication chart that follows in this section shows those items requiring regular service and the interval at which they should be performed. Details concerning the oil and other lubricants follow the lubrication chart. A regular service program should be geared to the items listed under each interval. These intervals are based on the average operating conditions. In the event of extremely severe, dusty, or wet operating conditions, more frequent lubrication than specified may be necessary.

- Specific recommendations of the brand and grade of lubricants are not made here due to regional availability, operating conditions, and also the continual development of the improved products. For more information, refer to component manufacturer's manual.
- All the oil levels are to be checked with the roller parked on a level surface and while the oil is cold, unless otherwise specified.
- On plug type check points, the oil levels are to be at the bottom edge of the check port.
- All the grease fittings are SAE standard unless otherwise indicated. Grease the non-sealed fittings until the grease is seen extruding from the fitting. One ounce (28 grams) of EP-MPG equals one pump on a standard one pound (0.45 kg) grease gun.
- Over lubrication on the non-sealed fittings will not harm the fittings or components, but under-lubrication will definitely lead to a shorter lifetime.
- Grease fittings that are worn and do not hold the grease gun or those that have a stuck check ball must be replaced.

To prevent the minor irregularities from developing into serious conditions, several other services or checks are recommended for the same intervals as the periodic lubrication:

- Thoroughly wash all the fittings, caps, plugs, and the like with a non-flammable and non-toxic cleaning solution before servicing to prevent dirt from entering while performing the service. During the regular lubrication service, visually check the entire unit with regard to capscrews, nuts, and bolts being properly secured.
- Spot check the several capscrews and the nuts for proper torque. If any are found loose, a more thorough investigation must be made.
- If a defect is detected, that requires special service, stop the roller operation until the defect has been corrected. If necessary, contact the Dynapac representative for assistance.



Lubrication Chart

Periodic lubrication requirements are listed in the following Lubrication Chart. These requirements include lubricant checks and greasing designated areas of the roller.

Description	Part Number	Remarks	Quantity
Engine oil	4812161855	Dynapac engine oil 50	5 L (1.3 gallons)
Hydraulic oil	4812161868	Dynapac hydraulic 300	20 L (5.3 gallons)
Drum oil	4812161887	Dynapac Drum oil 1000	7L (1.8 gallons)
Coolant	4812161854	Dynapac coolant 100	20 L (5.3 gallons)
Drum gear oil	4812161858	Dynapac Gear oil 400	5L (1.3 gallons)













Refill Capacities

The following fluid capacities are provided for the servicing personnel who must perform roller maintenance in the remote locations where complete shop facilities and resources are not available. These capacities will give the servicing personnel an approximation of the fluid capacities of the components to be serviced. Always use the specified method to check for accurate fluid levels.

Component	Approx. Quantity
Systems	
Hydraulic Tank	45 L (11.9 gallons)
Engine	
Engine Coolant	12L (13.17 gal) Coolant + 8L (2.1 gal) Water
Engine Oil Capacity	10 L (2.6 gallons)
Fuel Tank	50 L (13.2 gallons)
Drum	5 L (1.3 gallons)



Table 7-8: Maintenance Symbols

Symbol	Description	Symbol	Description
	Engine oil level		Air filter
	Engine oil filter		Battery
	Hydraulic reservoir level		Sprinkler
	Hydraulic fluid filter		Sprinkler water
	Drum oil level		Recycling
	Lubrication oil		Fuel filter



7.4 Standard Torque Values



Use only the proper tools (inches) on hardware. Other tools may not fit properly and may slip and cause injury.

Head Markings

Fasteners should be replaced with the same grade or a higher grade. If higher grade fasteners are used, these should only be tightened to the strength of the original grade fastener.

Do not use these values if a different torque value or the tightening procedure is listed for a specific application. Torque values listed are for general use only. All values are suggested maximum with dry plated hardware.

Make sure fastener threads are clean and you properly start thread engagement. This will prevent them from falling when tightening.

The following pages list the recommended tightening torques for the various size bolts used for the machine. Proper torque specifications should be used at all times.

Recommended Torques

This page lists the recommended tightening torques, in foot/pounds (ft·lb), for the various size bolts and nuts that are used. Proper torque specifications should be used at all times. Dry means clean dry threads and lube means a light film of oil. Excess oil in a threaded dead end hole can create a hydraulic lock giving false torque readings. Suggested assembly torque values are per engineering specifications.

M-thread Size	Metric coarse screw thread, bright galvanized (fzb):					
	8.8 Oiled	8.8 Dry	10.9 Oiled	10.9, Dry	12.9, Oiled	12.9, Dry
M6	8,4	9,4	12	13,4	14,6	16,3
M8	21	23	28	32	34	38
M10	40	45	56	62	68	76
M12	70	78	98	110	117	131
M14	110	123	156	174	187	208
M16	169	190	240	270	290	320
M20	330	370	470	520	560	620
M22	446	497	626	699	752	839



M-thread Size	Metric coarse screw thread, bright galvanized (fzb):					
	8.8 Oiled	8.8 Dry	10.9 Oiled	10.9, Dry	12.9, Oiled	12.9, Dry
M24	570	640	800	900	960	1080
M30	1130	1260	1580	1770	1900	2100

M-thread Size	Metric coarse thread, zinc-treated (Dacromet/GEOMET)			
	10.9 Oiled	10.9 Dry	12.9 Oiled	12.9 Dry
M6	120	150	146	183
M8	28	36	34	43
M10	56	70	68	86
M12	98	124	117	147
M14	156	196	187	234
M16	240	304	290	360
M20	470	585	560	698
M22	626	786	752	944
M24	800	1010	960	1215
M30	1580	1990	1900	2360

Bolt dimensions	M16 (PN 902889)
Strength class	10.9
Tightening torque	192 Nm, torque class 2 (Dacromet treated)



7.5 Maintenance as Required

Service as Required

The preventive maintenance and service in this section requires attention on the need basis, before, during, and after the operation shift. This is in addition to the 8 to 10 hour daily routine maintenance procedures. Performance of this inspection can result in longer life and maximum productivity from the roller. Refer to the manufacturer's service manuals for maintenance and service on the carrier.

Clean the Roller

The complete roller must be given a weekly cleaning. Daily cleaning will be required if material is adhering to the machine working parts.

- Make sure the operator areas, steps, and grab rails are clean. Oil, grease, snow, ice, or mud in these areas can cause to slip and fall. Clean the boots of excess mud before getting in the roller.
- Thoroughly wash all fittings, caps, plugs, and the like with a non flammable, nontoxic cleaning solution before servicing to prevent dirt from entering while performing the service.
- After cleaning, check for defects in the air cleaner ducts.
 - a. Check intake for accumulation of debris that could restrict air flow.
 - b. Check the air cleaner mounting hardware for security.
 - c. Check all hoses for cracks, chafing, or deterioration and replace at the first sign of probable failure.

Loose Bolted Connections

If any loose nuts or bolts are found during the frequent walk-around and the daily inspections, make sure they are properly torqued. Refer to **7.4 Standard Torque Values** for the required torque for all bolt sizes and grades. Always replace self-locking nuts if they have been loosened.

Air Cleaners

The following are detailed instructions for performing routine maintenance procedures on the air cleaner.



Raw, unfiltered air can damage the roller. Never service the air cleaner while the roller is running.



Airborne dust may be hazardous. Wear proper personal protective equipment while handling air cleaners and elements.

Air Cleaner Indicators

Check the air cleaner visual restriction indicator before and after every shift.

If the indicator on the air cleaner turns red, replace the main filter on the air cleaner. The dust pouch is emptied by pressing the rubber bellows with your fingers. Check also that the air hoses are in good condition. Clean the air cleaner when operated in extremely dusty environments.



Connections and Ducts

Check air cleaner and ducts for leaks before every shift, during every shift, and after every shift. Make sure all connections between the air cleaner and air compressor are tight and sealed.

Note Dust that gets by the air cleaner system can often be detected by looking for dust streaks on the air transfer tubing or just inside the intake manifold inlet.

Air Cleaner Pre-Cleaner

Wipe clean the inside of the cover and the filter housing. Wipe also both surfaces for the outlet pipe.

Note Check that the hose clamps between the filter housing and the suction hose are tight and that the hoses are intact. Inspect the entire hose system, all the way to the engine.

Figure 7-1: Pre-Cleaner

Wipe clean on both sides of the outlet pipe.

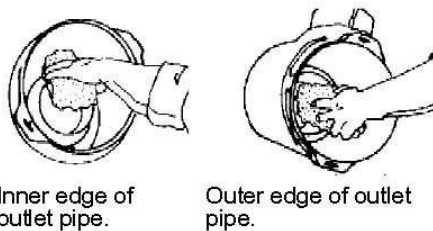

Inner edge of outlet pipe.

Outer edge of outlet pipe.



Never clean Dono clone tubes with compressed air unless both the safety and primary elements are installed in the air cleaner. Do not steam clean the tubes in the pre-cleaner.

Air Cleaner Main Filter

The air cleaner is the dry type with two elements; a main filter that is replaceable and can be cleaned, and a backup filter that should only be replaced and never cleaned.

Figure 7-2: Air Cleaner Elements

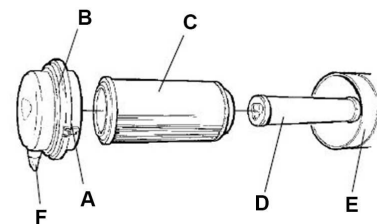

A	Clips	D	Backup filter
B	Cover	E	Filter housing
C	Main filter	F	Dust valve

When the visual restriction indicator is red, clean and replace the air cleaner elements. The following maintenance procedure must be followed.

1. Unclip the clamps holding the main filter.
2. Remove the washer. Carefully withdraw the main filter.
3. Inspect the main filter indicator (safety signal). If the indicator is red, replace the main filter.

Note Make sure new elements arrive enclosed in plastic or in a protective membrane. Do not install elements that are unprotected. This is a dust hazard.

Note Never attempt to clean a backup filter. Change the backup filter whenever main filter replaced.

4. Examine the new or newly cleaned main filter for torn or damaged pleats, bent end covers, liners, and gaskets.



5. Make sure the main filter washer are not cracked or damaged. Replace if necessary.
6. The backup filter should be replaced if the air cleaner visual restriction indicator is red after servicing the main filter.
7. Clean the inside of the air cleaner housing before removing backup filter.
8. To replace the backup filter, remove the old filter from the holder. Dispose of the used element properly.
9. Install new backup filter into the holder.
10. Carefully install the cleaned or new main filter.

Figure 7-3: Air Filter

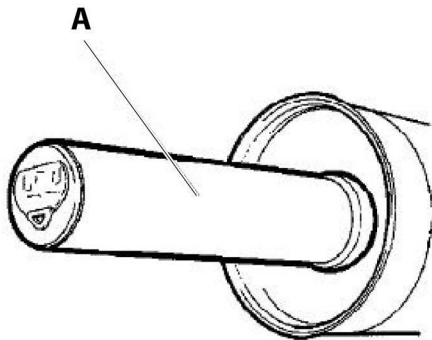

A Backup filter

11. Re-install the back cover, make sure the dust valve is positioned downwards.
12. Inspect all air intake piping and joints between the air cleaner and inspect the air inlet to make sure that no dusty air can enter.

After servicing the elements, reset the restriction indicator to green when the element is replaced in the air cleaner housing.

Note Never leave the air cleaner open longer than necessary.

Note The two most common servicing problems are over servicing and improper servicing.

Air Circulation

Check that the engine has free circulation of cooling air through the grille in the engine compartment.

Figure 7-4: Air Circulation

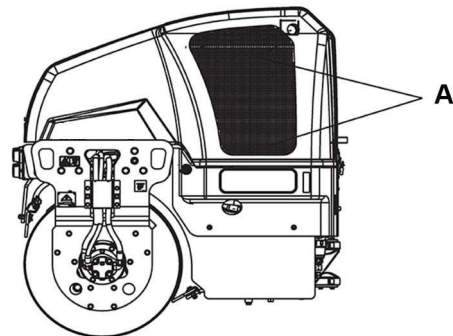

A Cooling air grille

Hose and Clamps

1. Periodic clamping bolts re-tightening is necessary due to cold-flow present in all rubber hoses. Tighten the boss clamps.
2. Examine and change out worn hoses and weakened Boss clamps. If hoses are to be changed out, change the Boss clamps also. Boss clamps hold the hose connections under a large amount of pressure. Boss clamps (including nuts and bolts) are for single use only. Do not reuse. Once removed, discard them.



Engine

Refer to the engine service and maintenance manuals for specific information on the engine maintenance.

Note Switch off the engine before filling the oil.

Note Care must be taken while draining the oil. Wear protective gloves and eye glasses.

1. Change the engine oil after 250 hours of operation.
2. Remove the oil filler cap and oil drain plug. Drain the oil into a suitable container.
3. Reinstall the drain plug and tighten.
4. Remove and replace the oil filter.

Figure 7-5: Fuel Filters

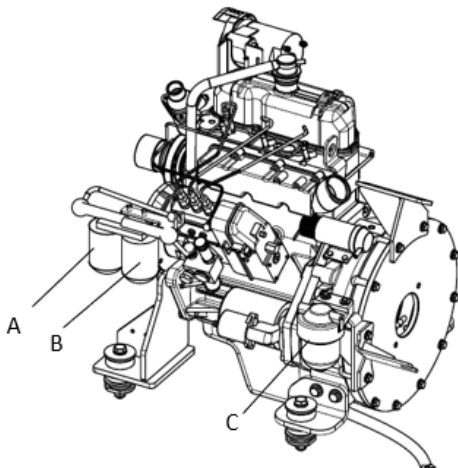

- A Mud filter
- B Fuel filter
- C Water Separator

5. Remove the oil filler cap and fill the engine crank case with recommended oil.
6. Start the engine and allow it to idle for a few minutes. During this time, check around the oil filter and drain plug for leaks.
7. Install the oil filler cap.

Batteries

The following battery maintenance must be carried out as part of the 250 hour routine maintenance schedule.



Batteries contain an acid and can cause injury. Skin and eye contact with battery fluid can cause injury. Avoid skin and eye contact with battery fluid. If contact occurs, flush area immediately with water.



Battery fumes can ignite and explode. Do not smoke when observing battery fluid level.

Note When disconnecting the battery, always disconnect the negative cable first. When connecting the battery, always connect the positive cable first.

Note Always wear protective glasses when working with batteries. Wash hands after touching batteries and connectors. Use of gloves recommended.

Batteries, Clamps, and Cables

The standard batteries supplied are heavy duty lead acid type, requiring the following maintenance.

1. Keep the top of the batteries clean.
2. Clean the terminals.
3. Keep battery connections tight.
4. Apply a small amount of grease to the terminal connections to prevent corrosion.
5. Inspect the cables, clamps, and hold down brackets. Replace if necessary.



Check Electrolyte Level

1. Shut off the engine.
2. Lockout/tagout the roller as per the site specific procedure.
3. Check the electrolyte level and keep the electrolyte level above the plates. Fluid level is low when below ring or ring is visible and too high when slots are not visible.
4. Refill with distilled water, if necessary.



Over filling can cause poor performance or early failure.

5. Remove lockout / tagout.

Figure 7-6: Battery Location

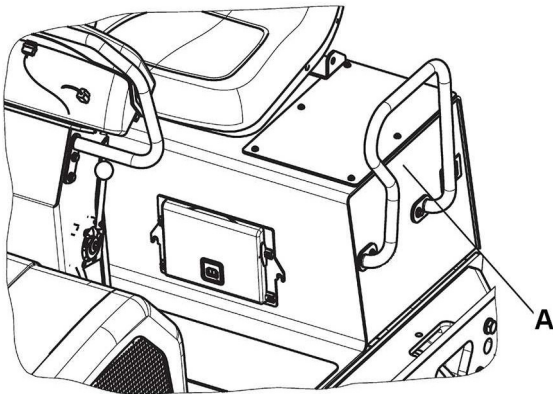

A Battery location

Fuel Tank

Refuel every day before starting to work.

1. Screw off the lockable tank cap.
2. Fill diesel fuel to the lower edge of the filler pipe.

Check fuel tanks and fuel lines for possible leaks. Because of the potential fire hazard, leaks must be corrected as soon as they are spotted.



Fuel is flammable. May cause serious injury or death. Shut off the engine, extinguish all open flames, and do not smoke while filling the fuel tanks. Always wipe up any spilled fuel immediately.

Check the fuel level by reading the fuel level gauge.

Never allow fuel tanks to completely empty.

Fill tank with the correct grade of fuel.

The fuel tank holds 50 liters.

Figure 7-7: Fuel Tank

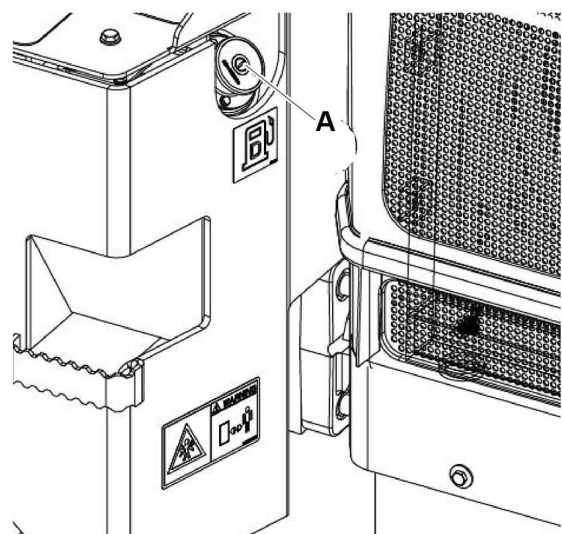

A Fuel tank

Coolant System

Check that all hoses/hose connectors are intact and tight. Fill with coolant as specified in the lubricants specification.

Change the coolant every year. Failure to cool the engine properly can result in engine failure or severely reduce engine life.

Figure 7-8: Coolant Level Gauge

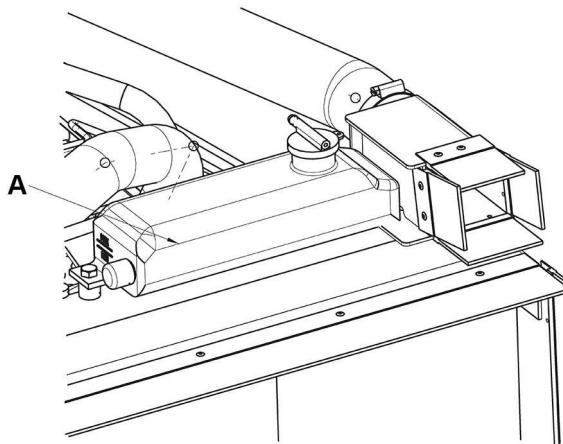

A Coolant level gauge



Personal injury can occur when removing the radiator cap. Steam or fluid escaping from the radiator can burn. Inhibitor contains alkali. Avoid contact with skin and eyes. Wear protective gloves and eye glasses.



Always shut off the engine and allow it to cool down before removing the radiator cap. Remove the radiator cap slowly to relieve pressure. Avoid contact with steam or escaping fluid.

Lowering of Engine Hood

1. Stand on the left side of the engine hood.
2. Press in the black rod and carefully lower the engine hood until the gas spring goes into the slot.
3. Release the black rod and then lower down the engine hood completely.

Figure 7-9: Lowering the Hood

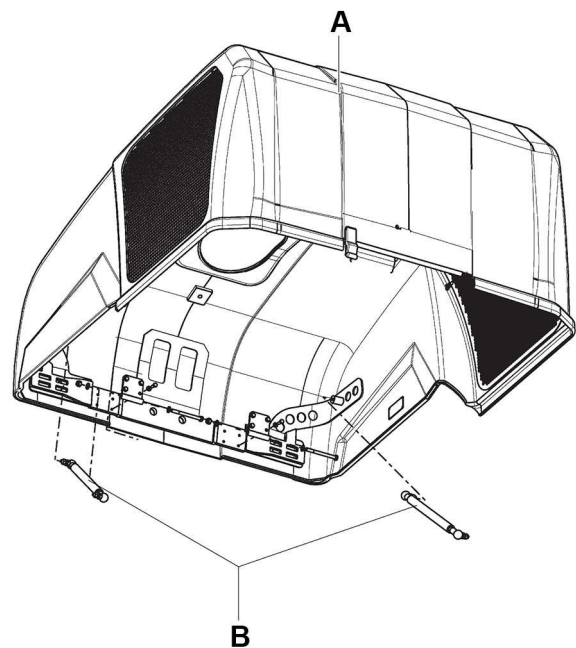

A Engine hood

B Gas spring



Water Tank

Unscrew the tank cap and fill with clean water. Do not remove the strainer. See technical specifications for the tank volume.

Note A small amount of environment-friendly antifreeze is added.

Figure 7-10: Water Tank

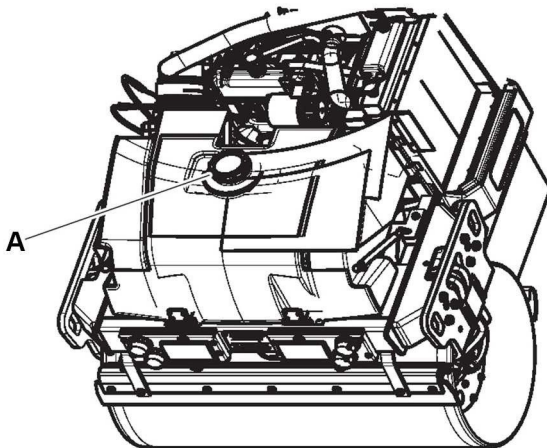

A Tank cap

Fixed Scrapers

Make sure that the scrapers are undamaged. Adjust the scrapers so that they are 1-2 mm from the drum. For special asphalt compounds, it may be better if the scraper blades lie lightly against the drums.

Asphalt remnants can accumulate on the scraper and affect the contact force. Clean as required.

1. Loosen the screws to adjust the contact pressure of the scraper blade against the drum.
2. Lock this setting by tightening the lock nut against the mounting plate.
3. Adjust the contact surface on both scraper attachments.

4. Tighten all the screws after adjustment.

Figure 7-11: Drum

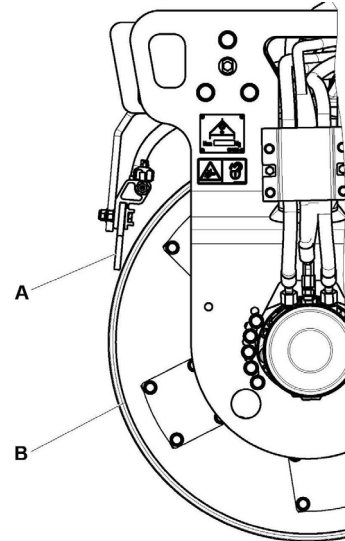

A Scraper blade

B Drum

The scrapers must be lifted from the drum during transport.

Brakes

Run the roller very slowly forward. Hold the steering wheel firmly and brace yourself for a sudden stop. Press in the emergency stop. The roller will stop abruptly and the engine will switch off. After testing the brakes, set the forward/reverse lever in neutral. Pull out the emergency stop. Start the engine. The roller is now ready for operation.



Sprinkler System

Start the sprinkler system and make sure that nonozzles are clogged. If necessary, clean clogged nozzles and the coarse filter located by the water pump.



The sprinkler system should be drained if there is a risk of freezing.

Wear protective eye glasses when working with compressed air.

Dismantle the blocked nozzle by hand. Blow the nozzle and fine filter clean with compressed air, or install replacement parts and clean the clogged parts later.

Figure 7-12: Sprinkler Pump

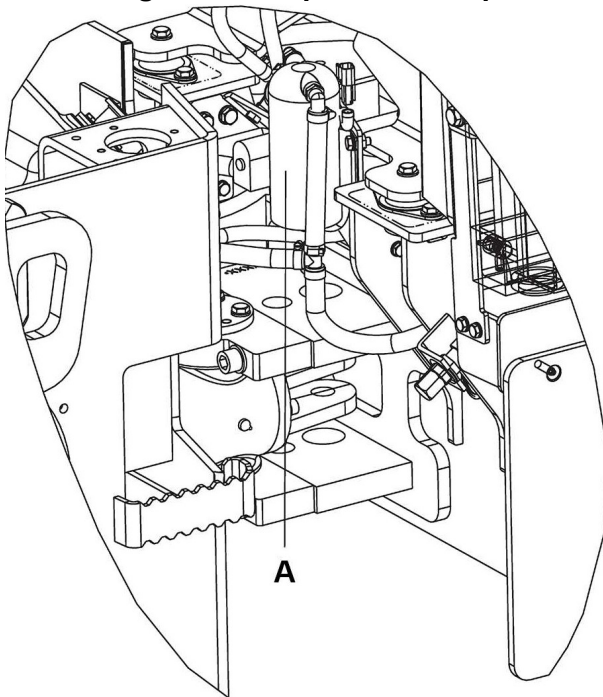

A Sprinkler pump



7.6 Lubrication and Filters

Hydraulic Reservoir

The hydraulic reservoir oil level must be checked daily as part of the 8 to 10 hour routine maintenance procedure.



Excessive hydraulic oil can rupture hydraulic tank and cause injury or property damage.

Note Take extra care when working around or on the hydraulic system to make sure its complete cleanliness. When operating, the oil level must be between the maximum and minimum levels. Top up with hydraulic fluid as per lubricant specifications if level is too low.

Note Dirt in the hydraulic system will lead to premature component failure. A clean, contaminant free system is extremely important for the roller to function properly.

Checking Hydraulic Oil Level

If the hydraulic oil level is low, add hydraulic oil.

1. Level the roller.

2. Check the reservoir oil level by viewing the sight gauge. Verify that fluid level is near the maximum level indicated on the sight glass.

Figure 7-13: Hydraulic Reservoir

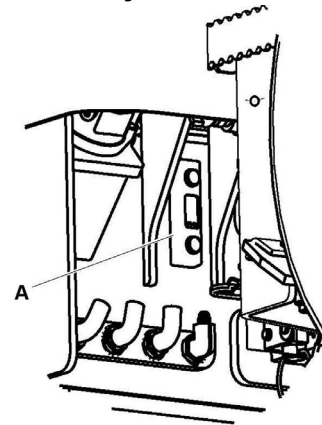

A Sight glass

3. Open the engine hood and unscrew the filler cap, top up with hydraulic fluid (as per lubricant specification) if the level is too low.

Figure 7-14: Hydraulic fluid Refilling

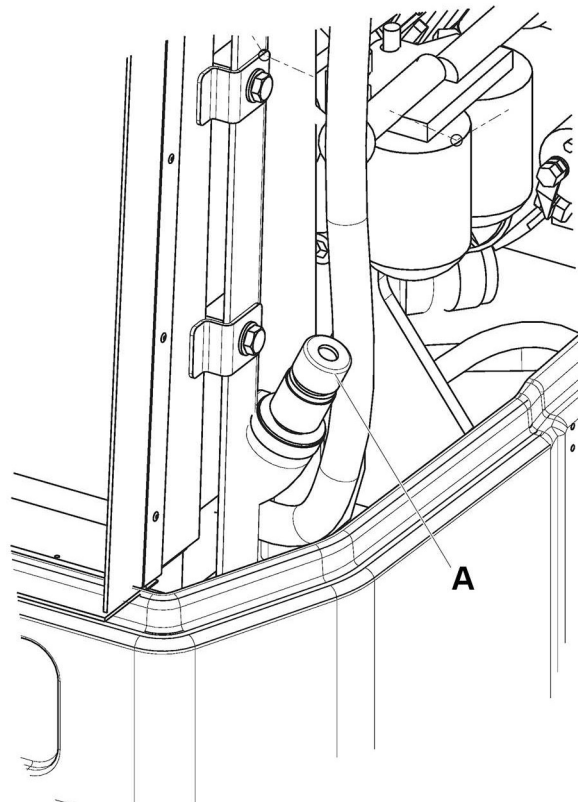

A Hydraulic fluid refilling



Steering Cylinder and Steering Joint

The steering cylinder is located under the operator's platform. There is a grease fitting near the base and rod ends of the cylinder.

1. Turn the steering wheel fully to the left. All four grease nipples can now be accessed from the right side of the machine.
2. Wipe the grease nipples.
3. Grease each nipple with five strokes of the hand-operated grease gun. Make sure that grease penetrates into the bearing. If grease does not penetrate the bearings, it may be necessary to relieve the articulation joint with a jack while repeating the greasing process.

Figure 7-15: Greasing

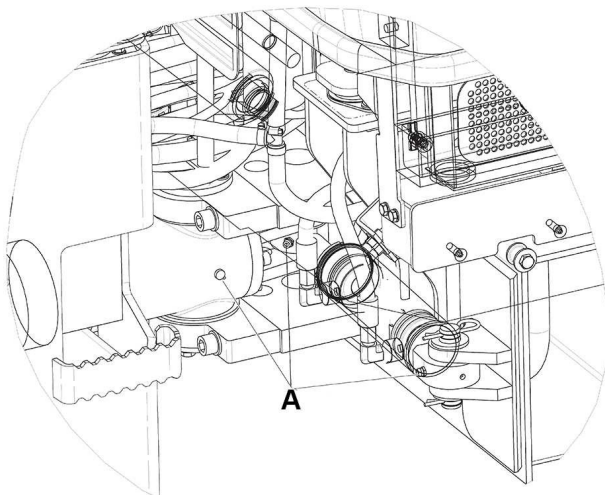

A Grease nipple

Drum - Oil Level

1. Run the roller slowly until the oil plug is opposite one of the inspection holes.
2. Unscrew the plug and check that the oil level reaches up to the bottom of the hole. Top up with new oil if necessary. Use oil as per the lubricant specification.
3. Clean the magnetic oil plug from any metallic residue, and refit the plug.

Figure 7-16: Drum Oil Filling

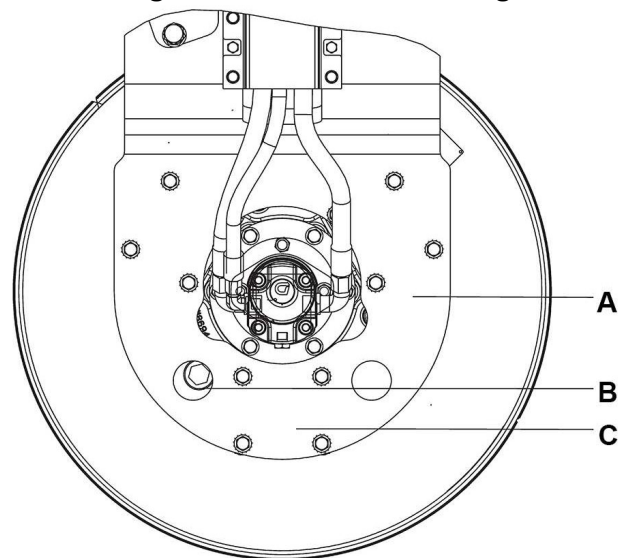

- A Filling
- B Level check
- C Drain

Controls

If the lever gets stiff after a prolonged period of use, remove the cover and lever and lubricate.

Lubricate the forward/reverse lever in the engine compartment with a few drops of oil.



Housekeeping

The complete roller must be given a weekly cleaning. Daily cleaning will be required if material is adhering to the roller working parts.

1. Make sure the operator areas, steps, and grab rails are clean. Oil, grease, snow, ice, or mud in these areas can be slippery. Clean the boots of excess mud before getting in the cab or on the roller operator platform.
2. Check the tower feed installation for debris buildup around the sheaves.
3. Thoroughly wash all fittings, caps, plugs, and the like with a nonflammable, nontoxic cleaning solution before servicing to prevent dirt from entering while performing the service.

Note Protect all electrical components and control panels against entry of water or steam when using high pressure cleaning methods. Cover the fuel and hydraulic fill cap breathers located on each tank.

4. After cleaning, check for defects in the air cleaner ducts.
 - a. Check intake for accumulation of debris that could restrict air flow.
 - b. Check air cleaner mounting hardware for security.
 - c. Check all hoses for cracks, chafing, or deterioration and replace at the first sign of probable failure.

This page is intentionally left blank



www.dynapac.com

Dynapac Road Construction Equipment (India) Pvt. Ltd.
Plot no 01, Gat no. 163-168, Alandi Markal road,
Village: Fulgaon, Taluka: Haveli, Dist: Pune- 412216, India