

INSTRUCTION MANUAL

RR200D

Reversible Plate



ENGINE:
GREAVES DIESEL
PART NUMBER :
4812334843



Table of Contents

1	Foreword	1
2	Safety Instruction	2
3	Safety Information Label Locations	3
4	Technical Specifications	6
5	Dimension	7
6	Transport	8
1	Transport to work site	8
2	Instruction for lifting machine	8
3	Operation	8
3.1	Engine check before starting	8
3.2	Starting the engine	8
3.3	Operating the machine	8
3.4	Stopping the engine operator position	8
8	Important Advice	9
1	Spare parts ordering	9
2	Scrapping	9
3	Main materials	9
4	Maintenance schedule	9
5	Maintenance	9
5.1	Monthly maintenance	9

Foreword

These operating and maintenance instructions are part of your machine.

They provide necessary information to operate your machine safely and properly.

They also contain information on required operating, maintenance and repair measures.

Carefully read the operating and maintenance instructions before taking your machine into operation.

Please observe the safety regulations strictly and follow all instructions to ensure safe operation.

The description of the individual operating steps including the notes on safety to be followed can be found in chapter "Operation"

Ensure the compliance with the specified operating, maintenance and repair measures to maintain the functional safety of your machine.

Do not service or repair your machine by yourself to avoid harming persons or damaging material or environment.

The machine must only be serviced and repaired by qualified and authorised personnel.

Contact our customer service to carry out the required maintenance work or necessary repairs.

In case of operating errors, inadequate maintenance or the use of unapproved fuels and lubricants all warranty claims will become null and void.

For your own personal safety you should only use original parts from REDLINE.

For your machine we offer service kits to make maintenance easier.

In the course of technical development we reserve the right for technical modifications without prior notification.

These operating and maintenance instructions are also available in other languages.

Apart from that, you can also order the spare parts catalogue against the serial number of your machine.

The above notes do not constitute an extension of the warranty and liability conditions specified in the general sales and delivery conditions of REDLINE GmbH.

We wish you successful work with your REDLINE machine.

Dynapac Road Construction Equipment (India) Pvt. Ltd.
Plot no 01, Gat no. 163-168, Alandi Markal road,
Village: Fulgaon, Taluka: Haveli, Dist: Pune- 412216, India
dynapac-redline.com





Safety Instruction

- Laws governing safety aspects on machinery may vary between countries but the following guides will be useful to all operators:
- Before starting, carefully read the machine maintenance and operating manual and follow all the instructions.
- Use unleaded fuel only, for gasoline engines.
- Never operate the machine without the belt guard.
- Keep hand and feet away from moving parts while the machine is running.
- Do not operate the machine in closed places and inflammable environment.
- Operating the machine is advisable only with good lighting conditions.
- Hearing protection must be worn.
- Foot protection must be worn.
- Do not touch hot surfaces.

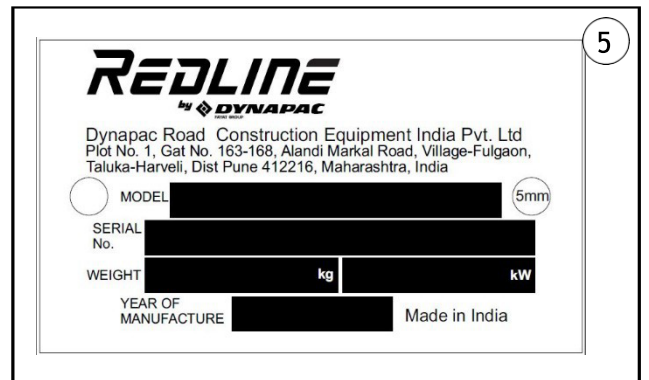
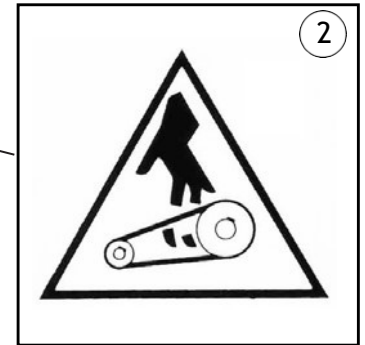
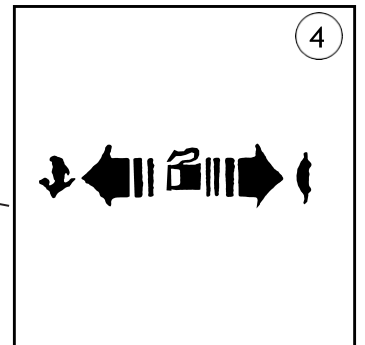
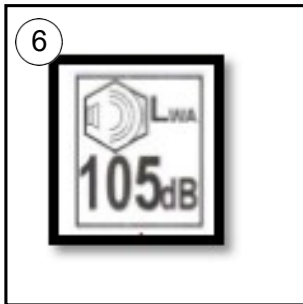
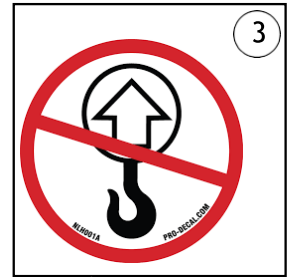
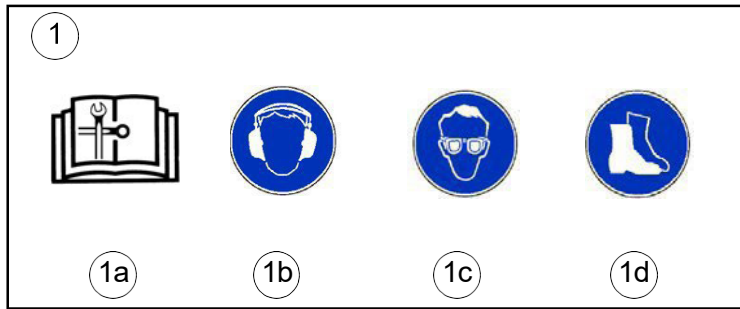





Safety Information Label Locations

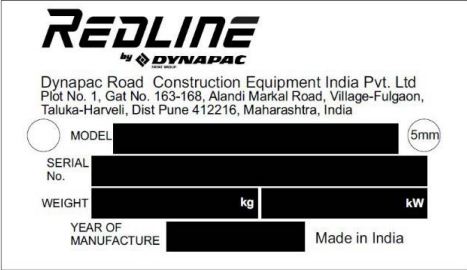

No.	Pictogram	Meaning
1a		<p>Read and understand the supplied operator's manual before operating this machine.</p>
1b		<p>Wear ear protection</p>
1c		<p>Wear eye protection</p>
1d		<p>Wear boots</p>

Operation Manual - Safety Information Label Locations

No.	Pictogram	Meaning
2		<p>WARNING! Hand injure if caught in moving belt. Always replace belt guard.</p>
3		<p>Information sticker - Not Lifting point</p>
4		<p>Operation sticker - Travel lever</p>
5		<p>A nameplate listing the model number, serialnumber, is attached to each unit. please record the information found on this plate so it will be available should the nameplate become lost or damaged.</p> <p>When ordering parts or requesting service information, you will always be asked to specify the model, item number of the unit.</p>
6		<p>Decibels Sticker</p>

Technical specifications

Models Cat. No.	RR200D - GREAVES DIESEL
Weight	
Net Weight kg.	196
Compaction data	
Vibr. Frequency Hz	81
Centrifugal Force kg.	3000
Compaction Area m ² /hour	600
Operation data	
Max. Traveling speed m/min	20
Capacities	
Oil for gear box liters SAE 15W/40	1.0
Drive motor	
Model	GREAVES DIESEL M11402.HRr
Output HP	5.0
Engine speed rpm	3600
Fuel tank - litres	3.6
Engine oil - litres SAE 15W/40	1.0
Noise and vibrations	
Sound power level according to ISO 5349 (*)	
Measured sound power level LwA=dB(A)	104
Vibration values a=m/s ²	The hand - arm vibration values according to ISO 5349
	2.3

(*) The above noise level and vibration values were determined at normal speed of the engine. During operation these values may differ because of the actual operational conditions.

Dimension

Handle in the working position

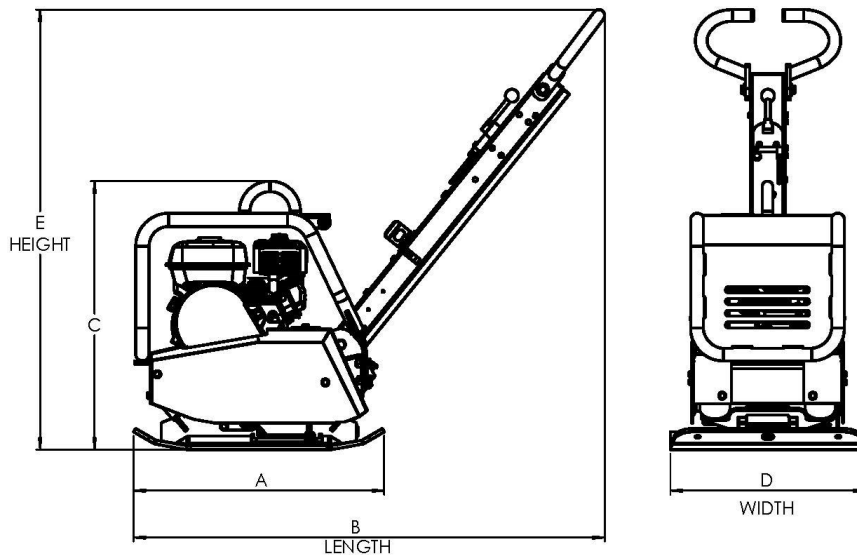

Handle in the folding position

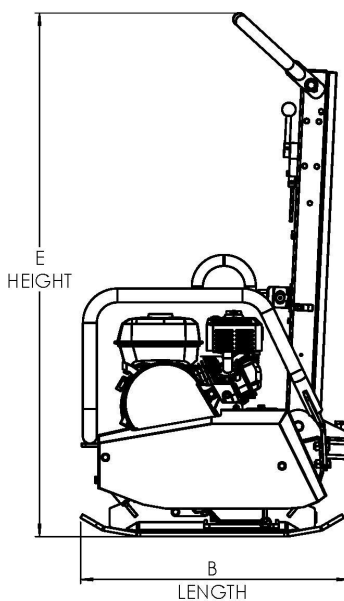

MODEL	A	B	B	C	D	E	E
	mm	Working Position	Folding Position	mm	mm	Working Position	Folding Position
RR200D	710	1370	795	770	500	1100	1125

Transport

1 Transport to work site:

- To avoid burns or fire hazards, let engine cool before transporting machine or storing indoors.
- Turn fuel valve to the off position and keep the engine level to prevent fuel from spilling.
- Tie the machine to the vehicle to prevent sliding or tipping over.

2 Instruction for lifting machine: see pictures 11 in [page 11](#)

- Never walk or stand under a machine being lifted.
- Use only the frame lifting hook (1) for lifting the machine.
- Use only tested and authorized lifting equipment. Before lifting check that vibration damper and protecting frame are correctly attached and not damaged.

3 Operation

Engine check before starting

1. Fill fuel tank.
2. Check oil level in engine crankcase and top up necessary type of oil according to manufacturer's instructions.

Starting the engine - see pictures 1-2 in [page 10](#)

1. Open handle locking pin (See Picture 1).

Operating the machine - see pictures 3-5 in [page 10](#)

1. Let the compactor progress at its normal speed while guiding it in a straight line.
2. Three or four passes depending on the material are normally required to achieve the best compaction.
3. The soil must be moist to achieve the best compaction.
4. It must not be too wet nor too dry so that dust is created.
5. Do not operate the compactor on hard surfaces or concrete.
6. Attach a polyurethane plate under the compactor when compacting paving stones. (Optional see picture 9 in [page 11](#))

Stopping the engine operator position

1. See Pictures 6-7 in [page 11](#)

Important advice

The manufacturer declines all responsibility for loss or damage resulting from misuse or any modification or alteration that does not conform to the manufacturer's original specifications.

At the workstation, the sound pressure level may exceed 85 db (A). In this case individual protection measures must be taken.

1 Spare parts ordering:

When ordering spare parts, please mention machine serial no., part no. and description.

2 Scrapping:

In the event of deterioration and scrapping of the machine, the following items must be disposed of in accordance with the requirements of the legislation in force.

3 Main materials:

1. Engine : Aluminum (AL), Steel (AC), Copper (CU), Polyamide (PA)
2. Machine : Steel sheet (AC)

NOTE

The instructions for use and spare parts found in this document are for information only and are not binding. As part of our product quality improvement policy, we reserve the right to make any and all technical modifications without prior notice.

4 Maintenance schedule:

Check all external screw connections for tight fit approx. 8 hours after first operation.		
Parts	Maintenance	Maintenance interval
Air filter	Check for external damage and tight fit. Check foam and filter insert clean or replace if necessary.	Daily
Engine oil other parts	Check oil level, top up if necessary. Remove all dirt, stones etc. from the compactor after each day of operation.	
Belt	Check tension and wear - replace if necessary.	Weekly
Engine	See engine manufacturers handbook	

5 Maintenance

Monthly maintenance:

- Perform maintenance work on engine according manufacturer's instructions.
- Check belt tightness and tighten if necessary.
- Belts should be move 10 -15 mm when pushed by the thumb (See picture 10 in [page 11](#)).
- Check and retighten bolts and nuts.

Starting the engine



Operating



Stopping the engine

