

REDLINE Asphalt & Concrete Cutter



RC185

Technical Data

Masses

Net mass	129 kg
Operating mass	135 kg

Cutting Section

Standard diamond cutting blade	510 mm
Optional diamond cutting blade	460 mm
Max. cutting depth	185 mm / 170 mm
Spindle diameter	25.4 mm
Water tank capacity	40 l

Engine

Manufacturer model	Honda GX390
Type	Petrol
Power	8.7 kW @ 3,600 rpm

Dimensions

Height H	1,115 mm
Length L	1,176 mm
Length L1	1,520 mm
Width W	585 mm

Features

- Variable cutting depth
- Two position lock for precise depth control
- Heavyduty quick connection for water spray system
- Four banded cogged Vbelt
- Allround protection for Vbelt
- Lifting hook
- Recoil starter
- Rust free water tank with painted interior

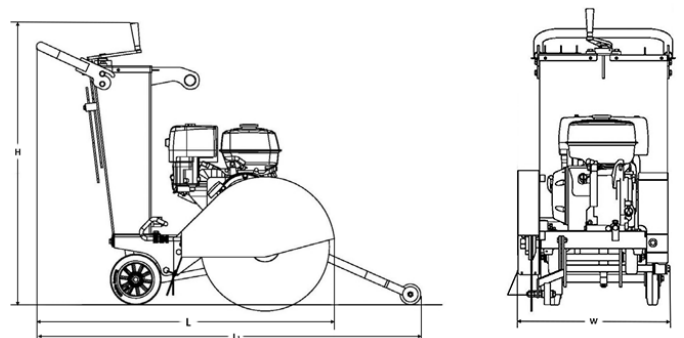

We reserve right to change specifications without notice. Photos and illustrations do not always show standard versions of machines.

The above information is a general description only, all information are supplied without liability.

