

# REDLINE Reversible



## RR150

### Technical Data

Masses		Features	
Operating mass	151 kg	Control handle with vibration isolation	
Net weight	149 kg	Control lever lock in transport position	
Gradeability		Reverse drive protection	
Maximum working speed	20 m/min	High wear resistant base plate	
Max gradability	46.6 %	All around protection hood	
Compaction		All around protection for Vbelt	
Centrifugal force	24 kN	One point lift	
Frequency	92 Hz	Recoil started	
Amplitude	1.65 mm	Selfcleaning plate technology	
Engine		High wearresistant forged base plate	
Manufacturer Model	Honda GX 160		
Type	Petrol		
Power	3.6 kW @ 3600 rpm		
Dimensions			
Height (H)	690 mm		
Height (H1)	1140 mm		
Height (H2)	1150 mm		
Length (L1)	1120 mm		
Length plate (L)	642 mm		
Width plate (W)	500 mm		

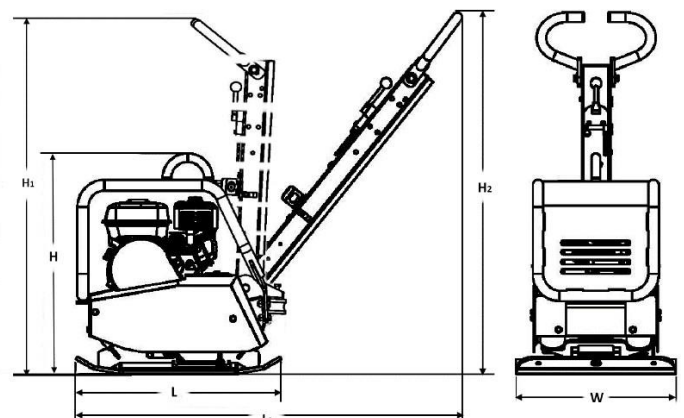

We reserve right to change specifications without notice. Photos and illustrations do not always show standard versions of machines.

The above information is a general description only, all information are supplied without liability.

