

REDLINE Forward Plates



RV80

Technical Data

Masses		Features
Operating mass	78 kg	Foldable steering handle with vibration isolation
Basic mass	67 kg	Highly wear resistance wear plate
Traction		Allround protection for Vbelt
Maximum working speed	26 m/min	Protection frame for the power pack
Max. Gradability	36.4 %	Carrying handles
Compaction		One point lift
Centrifugal force	12 kN	Punctureproof transport wheels
Frequency	93 Hz	
Amplitude	1.44 mm	
Engine		
Manufacturer Model	Honda GX 160	
Type	Petrol	
Power	3.6 kW @ 3,600 rpm	
Dimensions		
Height (H)	650 mm	
Height (H1)	900 mm	
Length (L)	550 mm	
Length plate (L1)	790 mm	
Width plate	350 mm	

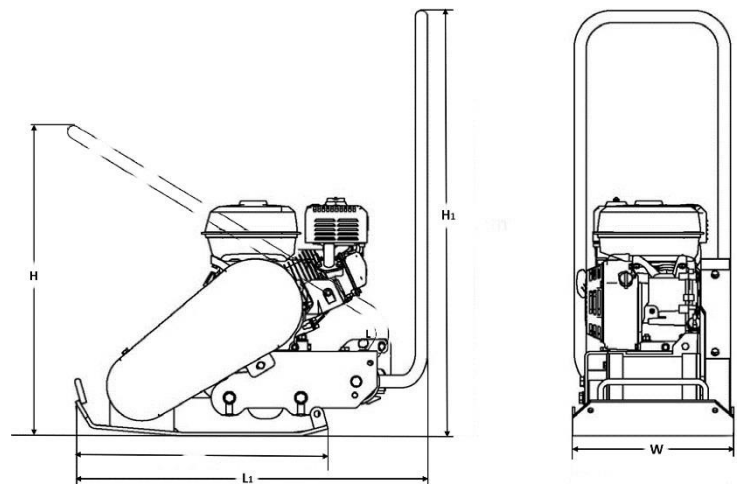

We reserve right to change specifications without notice. Photos and illustrations do not always show standard versions of machines.

The above information is a general description only, all information are supplied without liability.

